

PLUS TWP-2UT WIRELESS TRANSMITTER



PLUS TWP-2UT Wireless Transmitter System is a solution to easily gather the temperature data needed to identify production issues and implement measures to increase efficiency and prevent future disruptions.

PLUS TWP-2UT Wireless Transmitter was designed to monitor universal temperature inputs, providing a secure communication, without cable requirements of a complex wired solution.

Dimensions: 120 x 90 x 50 mm

Weight: 314 g

Material: ASA+PC-FR (UL 94 V-0) / Polycarbonate

Protection Index: IP65

KEY FEATURES

2 UNIVERSAL TEMPERATURE INPUTS

1 REMOTE SWITCH OUTPUT

UP TO 4 KM COMMUNICATION DISTANCE (LOS)

MULTI-HOP MESH NETWORK

WITH SELF-FORMING, SELF-HEALING AND SELF-OPTIMIZING FEATURES

OPERATING MODE

AS END DEVICE / AS REPEATER

SITE SURVEY FEATURE

SIMPLE AND INTUITIVE USB CONFIGURATION

TEKON CONFIGURATOR SOFTWARE

DS_PLUS_TWP-2UT_E01C

TECHNICAL SPECIFICATIONS

RADIO SPECIFICATIONS	868MHZ	915MHZ
Range ¹	Up to 4Km LoS	
Frequency Band	868 to 869MHz	902 to 928MHz ⁴
Radio channels	16	50 ⁵
Radio receiver sensitivity ²	-97 to -110 dBm	
Power ²	25 to 27 dBm	8 to 27 dBm
Radio transmission rate ²	19 to 76,8kbit/s	
Encryption method	AES 128 (Advanced Encryption Standard)	
Modulation	GFSK	
Connection	SMA	
Antenna	Articulated dipole antenna	
Antenna impedance	50Ω	

WIRELESS NETWORK	
Maximum devices	55
Maximum hops	13
Communication period	1 to 43200 seconds (configurable) ⁷

INTERNAL TEMPERATURE	
Range	-30 to 80°C
Resolution	0,01°C
Accuracy	± 0,50°C
Sensor type	NTC

INPUT RESISTANCE THERMOMETER (RTD)	
Measured variable	Temperature
Sensor type	PT100
Units	°C
Connection	1 Resistance thermometer (RTD) in 2, 3 and 4-wire system
Sensor current	200µA
Open-circuit monitoring	Always active (cannot be disabled)
Short-circuit monitoring	Always active (cannot be disabled)
Measuring range	See "Digital measuring accuracy" table
Cable resistance per wire (max.)	50 Ω

INPUT THERMOCOUPLES (TC)	
Measured variable	Temperature
Sensor type	Thermocouples: C, J, K, N, R, S, T
Units	°C
Connection	1 Thermocouple
Open-circuit monitoring	Always active (cannot be disabled)
Short-circuit monitoring	Not available
Cold junction compensation (CJC)	Integrated resistance thermometer

Measuring range	See “Digital measuring accuracy” table
-----------------	--

MEASUREMENT ACCURACY

Reference conditions	
Power supply	12V DC ± 1%
Ambient temperature	23°C
Digital measuring errors	See table “Digital measuring accuracy” table
Internal cold junction	
Accuracy	< ± 0,50 °C
Resolution	0,01 °C
Influence of ambient temperature	
on RTD measurement	< ± 0,001 °C / °C
on thermocouple	Thermocouples C, J, K, N, T: ≤ ± 0,005 °C / °C Thermocouple R: ≤ ± 0,010 °C / °C Thermocouple S: ≤ ± 0,2 °C / °C

DIGITAL OUTPUT - REMOTE OUTPUT

Range	5 to 24V DC
Type	Sinking / NPN
Maximum current protection	90mA
Start state	ON / OFF / last state ³
Communication loss state	ON / OFF / last state ³
Event number activation	N/A
Activation period before communication	N/A

POWER SUPPLY

Supply voltage	5 to 24V DC ± 5% / USB ⁶
Maximum current	500mA DC @ 5V DC / 100mA DC @ 24V DC
Protection against reverse polarity	

INTERFACE

Indication	Frontal Panel LED
Switches	External - Site Survey activation Internal - Load Default Factory Settings
Configuration	Internal micro USB connector

MECHANICAL INTERFACE

Push-in spring terminal blocks (internal)	
Bucins PG-7	
1.5mm ² (0.0591in ²)	
Micro USB internal connector	

OPERATING ENVIRONMENT	ENVIRONMENTAL CONDITIONS	STORAGE CONDITIONS
Temperature		-30 to 80°C
Relative humidity	N/A	≤ 95% (non- condensing)

CASING		
Dimensions	120 x 90 x 50 mm	
Weight	314 g	
Material	ASA+PC-FR (UL 94 V-0) / Polycarbonate	
Protection index	IP65	
FACTORY DEFAULT SETTINGS		
	868MHZ	915MHZ
Frequency	869,525MHz	915,000MHz
Radio transmit power	27dBm	
Radio transmission rate	76,8kbit/s	
Wireless channel	13	26
Wireless network ID	13042017	
Communication period	10 seconds	
Reconnection period	30 minutes	
Gateway modbus index	1	
Sensor Input 1/2	PT100 3W / PT100 3W	
Digital output - Remote output	OFF	
Operating mode	End Device	

CERTIFICATIONS AND APPROVALS
EN 61326-1 - Class B - Industrial Requirements
EN 300 220-2 V3.1.1
EN 301 489-1 V2.2.1
EN 301 489-3 V2.1.1
EN 60950-1:206
EN 61326-1:2013
ETSI EN 301 489-1 V1.9.2

¹ Range depends on the RF propagation environment and Line of Sight (LoS). Always verify your wireless network's range by performing a Site Survey

² Dependent on radio channel selection

³ Configurable

⁴ In some countries, the frequency band admitted is not so extended as the default range.

⁵ The radio frequencies admitted in Australia are available from channel 26 to channel 50.

⁶ It is recommended to use a power supply with short-circuit current protection or equipped with a fuse.

⁷ As there are two temperature sensors, the measurement is carried out and information is sent to each sensor. For a communication period of 1 second, it takes 2 seconds to perform the measurement and send the two temperature values.

DIGITAL MEASURING ACCURACY			
RESISTANCE THERMOMETER (RTD)			
Sensor	Range °C	Accuracy °C	Resolution °C
PT100	-210 to 850	< ± 0,2	0,05
THERMOCOUPLES (TC)			
Sensor	Range °C	Accuracy °C	Resolution °C
C	0 to 2300	< ± 1,0	0,400
J	-210 to 1200	< ± 1,0	0,077
K	-270 to 1370	< ± 1,0	0,098
N	-270 to 1270	< ± 1,0	0,151
R	-50 to 1760	< ± 1,2	0,189
S	-50 to 1760	< ± 2,0	0,185
T	-270 to 400	< ± 1,0	0,026

TECHNICAL DRAWINGS

DIMENSIONAL DRAWINGS AND INTERFACE DESIGN

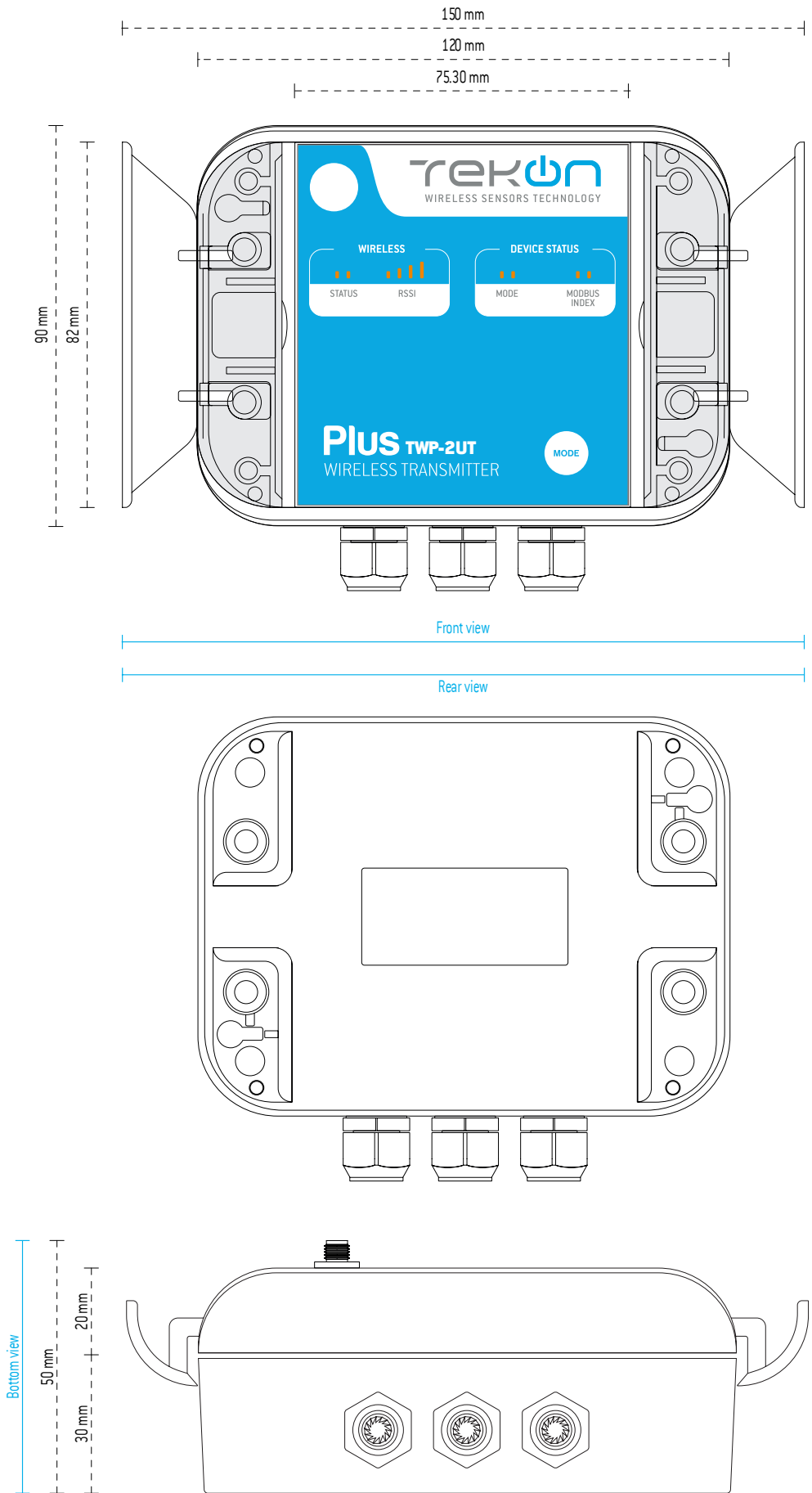

WIRING DIAGRAM

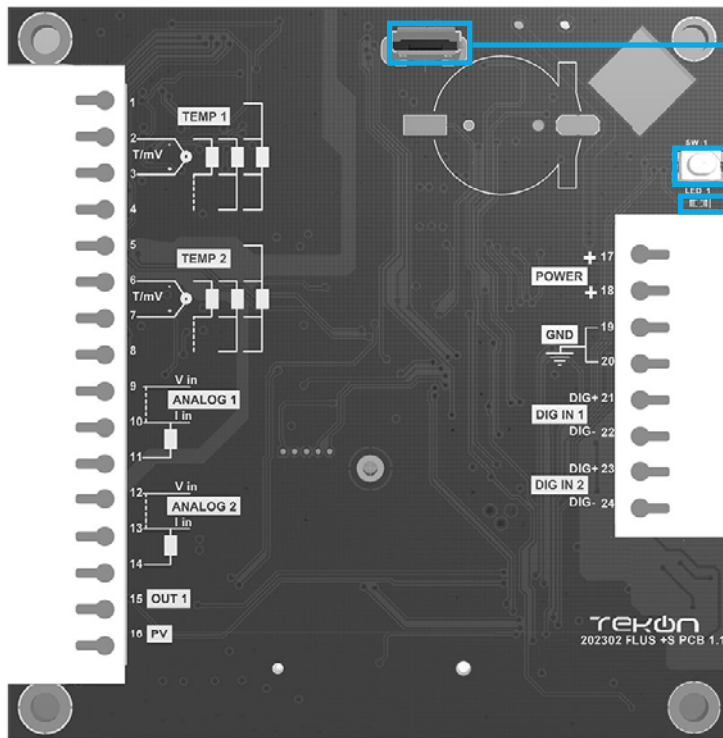

USB Configuration Port
Allows Tekon device Configuration

- Load factory setting button (2 methods)**
- Pressing this button during 3 seconds forces the factory settings load and reboot.
 - Power ON the device with the button pressed during 3 seconds forces the factory settings load and reboot

Internal LED

Digital Output - SINKING - NPN

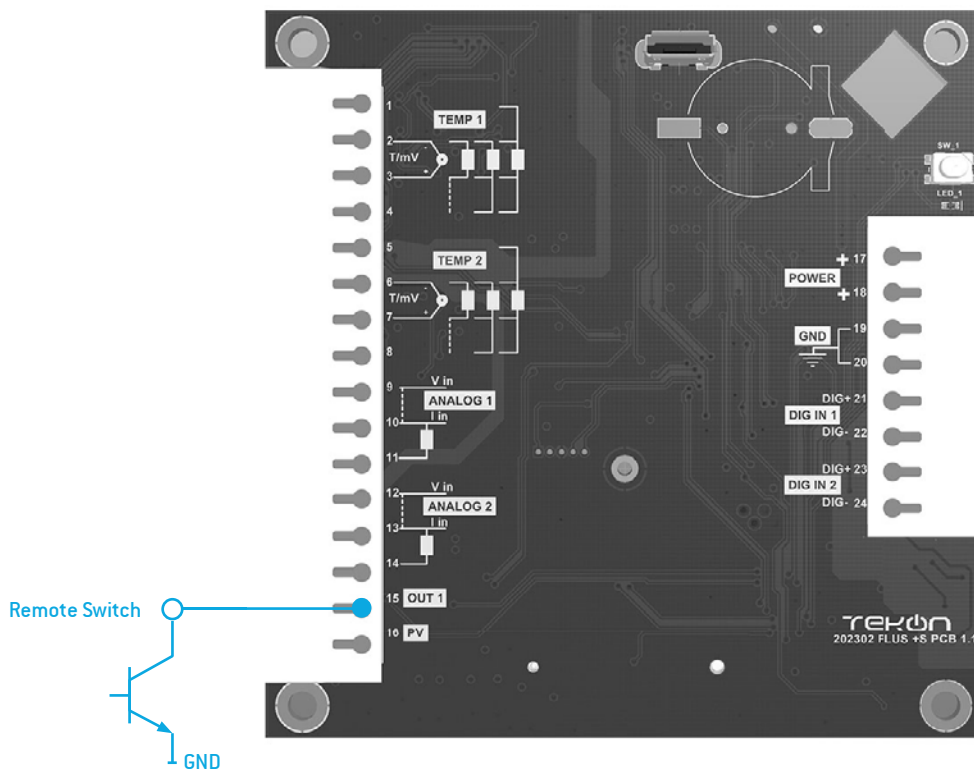

Universal Temperature Input

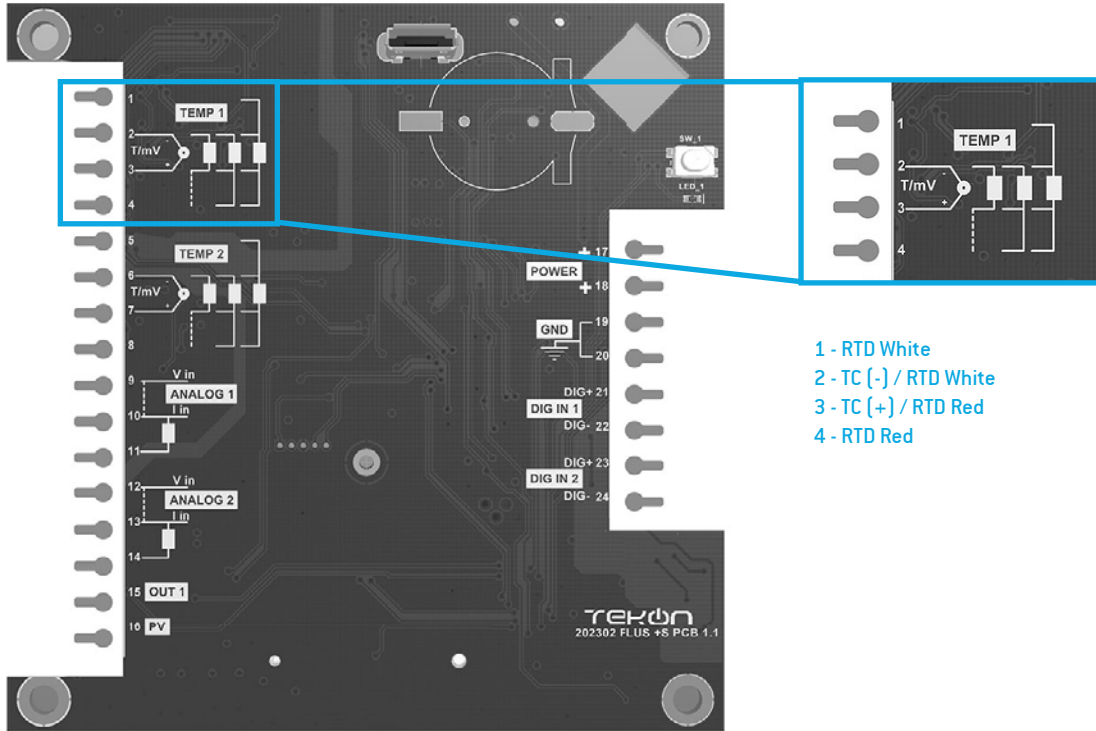

Transmitter

PIN	Functionality	Functionality		
		2 Wires	3 Wires	4 Wires
1	Temperature Input 1			(-)
2		(-)	(-)	(-)
3		(+)	(+)	(+)
4		Connect to pin 3	(+)	(+)
5	Temperature Input 2			(-)
6		(-)	(-)	(-)
7		(+)	(+)	(+)
8		Connect to pin 7	(+)	(+)
9	Not used			
10	Not used			
11	Not used			
12	Not used			
13	Not used			
14	Not used			
15	Remote Switch Output			
16	Battery Voltage			
17	Power Supply (+)			
18	Power Supply (+)			
19	Power Supply (GND)			
20	Power Supply (GND)			
21	Not used			
22	Not used			
23	Not used			
24	Not used			

REVISION HISTORY

VERSION	
E01B	Inclusion of observation on the process of measuring and sending information in relation to the communication period
E01C	Inclusion of Reconnection Period on “Factory Default Settings Table”

© BRESIMAR AUTOMAÇÃO, S.A.

All rights reserved.

The contents of this document (texts, images, brands, corporate image, trade name, designs, methodological and product descriptions, among others), as well as its structure and design, are owned by Bresimar Automação, SA (herein in referred to as Bresimar) or, it has legitimacy for its use, being strictly prohibited the modification, exploitation, reproduction, communication to third parties or distribution of all or part of the contents of this document, without the prior express written consent of Bresimar .

Bresimar will not be liable for any claim, loss or damages resulting from or arising from a cause over which Bresimar has no control, whether by acts or omissions, breach of contract or non-compliance with applicable laws by the Supplier , as well as incidents caused by the client’s systems.

TEKON ELECTRONICS
a brand of Bresimar Automação S.A.

Avenida Europa, 460
Quinta do Simão
3800-230 Aveiro
PORTUGAL

P.: +351 234 303 320
M.: +351 933 033 250
E.: sales@tekonelectronics.com

