

WIRELESS TEMPERATURE TRANSMITTER THW401

**LOW
POWER
OP. MODE**

**COMPACT
DESIGN**



The Universal Wireless Temperature Transmitter THW401 is specifically designed to meet the most rigorous requirements of operation in the industrial process environments. Due to its reduced dimensions, it may be installed in the DIN Form B sensor connection head, in place of the traditional terminal blocks or current loop temperature transmitter.

In its high RF power mode it can communicate over a long distance range (up to 4 Km line of sight).

It accepts the most commonly used temperature sensors.

Dimensions: 45 ϕ x 23 mm

Weight: 50g (approx.)

Material: Nylon 66

Protection Index: IP40

KEY FEATURES

UNIVERSAL SENSOR INPUT

RESISTANCE THERMOMETERS, THERMOCOUPLES AND DC VOLTAGE SOURCES

UP TO 4KM OR 2KM DISTANCE (LOS)

TRANSMISSION UP TO 4KM DISTANCE (LOS) 868 MHZ
TRANSMISSION UP TO 2KM DISTANCE (LOS) 2,4 GHZ

REAL TIME TRANSMISSION

PROCESS AND AMBIENT TEMPERATURE, RF SIGNAL STRENGTH AND BATTERY STATUS

ULTRA LOW POWER MODE

LONG BATTERY LIFE

WIDE SUPPLY VOLTAGE RANGE

5 TO 24 V DC

COMPACT DESIGN

DIN FORM B CONNECTION HEAD MOUNTING

DS_0NE_THW401_E01C

TECHNICAL SPECIFICATIONS

**INPUT
RESISTANCE THERMOMETER (RTD)**

Measured variable	Temperature
Sensor type	PT100, PT500, PT1000
Units	°C
Connection	1 Resistance thermometer (RTD) in 2-wire, 3-wire or 4-wire system
Sensor current	<0,05 mA (50µA)
Response time	<500 ms
Open-circuit monitoring	Always active (cannot be disabled)
Short-circuit monitoring	Always active (cannot be disabled)
Measuring range	See "Digital measuring accuracy thermometer" table

**INPUT
THERMOCOUPLES (TC)**

Measured variable	Temperature
Sensor type	E, J, K, N, R, S, T
Units	°C
Connection	1 Thermocouple
Sensor current	<0,05 mA (50µA)
Response time	<500 ms
Open-circuit monitoring	Always active (cannot be disabled)
Short-circuit monitoring	Not available
Cold junction compensation (CJC)	Integrated resistance thermometer
Measuring range	See "Digital measuring accuracy thermocouples" table

RADIO SPECIFICATIONS

	868 MHz	2,4 GHz
Range ¹	Up to 4km LoS, 27 dBm (500mW)	Up to 2km LoS, 10 dBm (10mW)
Frequency band	868 to 870 MHz ²	2,4 to 2,5 GHz ²
Number of channels	16	
Reception sensitivity	-97 to -109 dBm ²	-91 to -108 dBm ²
Transmit power	0 to 27 dBm ²	-10 to 18 dBm ²
Communication period	Adjustable from 1 second to 24h	

OUTPUT (RF TRANSMISSION)

Output signals	
Sensor value (Temperature / mV)	Temperature °C / mV
Internal Temperature	Temperature °C
RSSI	Absolute value
Power supply voltage	Voltage V
Configurable parameters	Sensor type, Communication period

¹ Range depends on the environment and line of sight. Always verify your wireless network's range by performing a Site Survey.

² Dependent on radio channel selection.

OPERATING ENVIRONMENT		868 MHz	2,4 GHz
Ambient temperature range		-40 to 80 °C	-20 to 80 °C
Storage temperature range		-40 to 80 °C	-20 to 80 °C
Relative humidity		≤ 95 %, without condensation	

POWER SUPPLY	
Voltage Range	5 to 24 V DC
Measurement accuracy	± 100mV
Power consumption (sleep)	< 0,2 mA
Battery Life	For a 9V battery, with 1200 mAh with a transmission interval of 2 minutes, the battery life is higher than 2 years

CASING	
Material	Nylon 66
Weight	Approx. 50g
Dimensions	See "Dimensional drawings"
Cross section	2,5 mm
Protection type	IP40

FACTORY DEFAULT SETTINGS	
Sensor	Thermocouple K
Measuring range	0...100°C
Transmission interval	300s
Wireless transmitter ID	0
Wireless network ID	0

CERTIFICATIONS AND APPROVALS	
EN 61326	Electrical equipment for measurement, control and laboratory use. EMC requirements.
IEC 61000-4-2	Electrostatic discharge immunity test
IEC 61000-4-3	Radiated, radio-frequency, electromagnetic field immunity test
IEC 61000-4-4	Electrical fast transient/burst/immunity test
IEC061000-4-5	Surge immunity test
EN 300 228	Electromagnetic compatibility and Radio spectrum Matters (ERM); Wideband transmission systems; Data transmission equipment operating in the 2,4 GHz ISM band and using wide band modulation techniques; Harmonized EN covering the essential requirements of article 3.2 of the R&TTE Directive
EN 300 440	Electromagnetic compatibility and Radio spectrum Matters (ERM); Short Range Devices; Radio equipment to be used in the 1 GHz to 40 GHz frequency range; Part 2: Harmonized EN under article 3.2 of the R&TTE Directive

MEASURING ACCURACY

MEASURING ACCURACY	
Reference conditions	
Auxiliary power	9V DC ± 1%
Ambient temperature	23°C
Warm-up time	>5min
Error due to internal cold junction	<0,5°C

Influence of ambient temperature

with resistance thermometers	0,06°C / 10°C
with thermocouples	0,6°C / 10°C

ACCURACY
RESISTANCE THERMOMETER (RTD)

Sensor	Range °	Digital accuracy °C
PT100	-200 to 850	0,1
PT500	-200 to 850	0,2
PT1000	-200 to 350	0,2

ACCURACY THERMOCOUPLES (TC)

Sensor	Range °C	Digital accuracy °C
E	-200 to 1000	1
J	-210 to 1200	1
K	-230 to 1370	1
N	-200 to 1300	1
R	-50 to 1760	2
S	-50 to 1760	2
T	-200 to 400	1

DIGITAL MEASUREMENT ACCURACY
MV

Sensor	Range (mV)	Accuracy
mV	- 8 to 100 mV	<40 μV

TECHNICAL DRAWINGS AND INFORMATION

BATTERY LIFE TIME

BATTERY LIFE TIME X REFRESH TIME

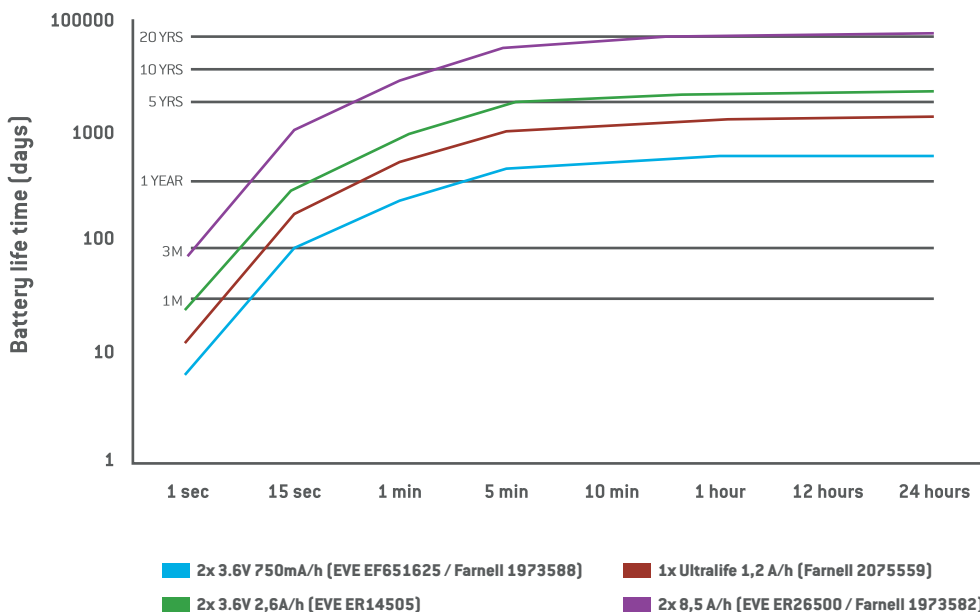

ELECTRICAL CONNECTIONS

RESISTANCE THERMOMETER

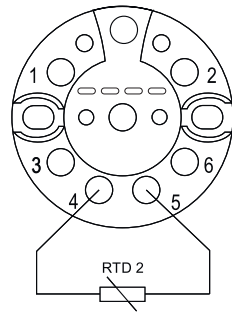

THERMOCOUPLE

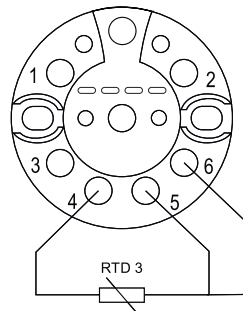
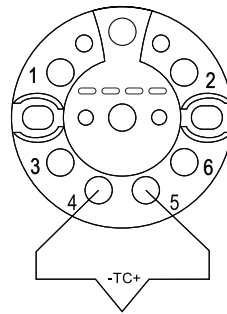

POWER SUPPLY (Uaux)

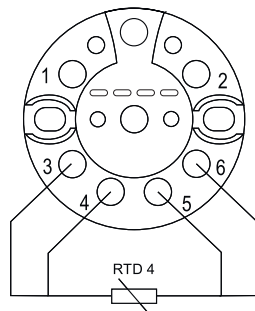
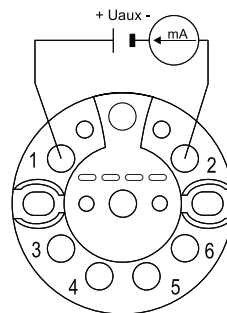

mV SENSOR

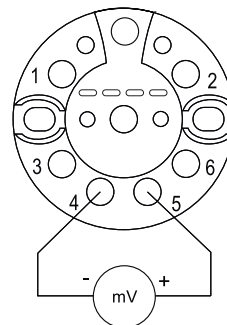

DIMENSIONAL DRAWINGS

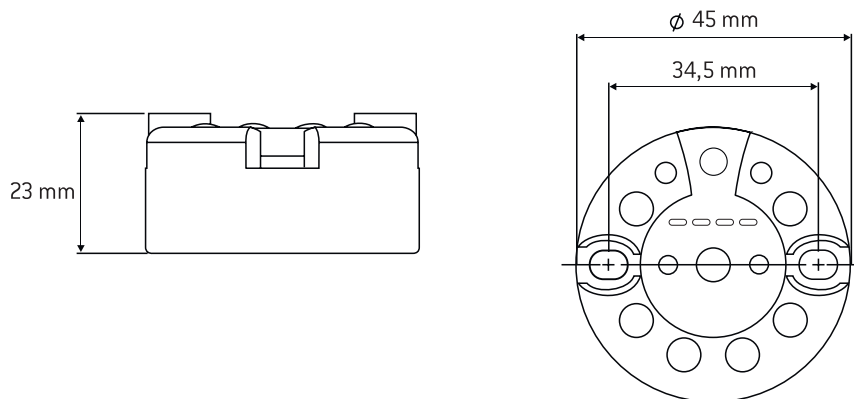

LED INDICATION IN CONNECTION AND CONFIGURATION

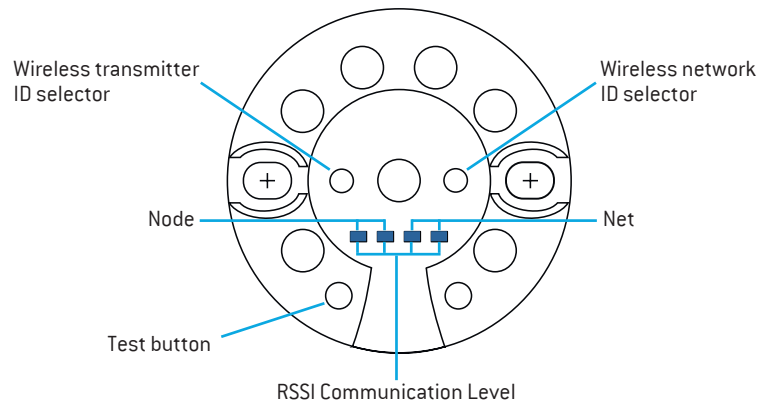

RELATED PRODUCTS



WG410 WIRELESS MODBUS GATEWAY 868MHZ AND 2,4GHZ WITH 8 ANALOG OUTPUTS

- Supports up to 16 THW401 temperature transmitters;
- 1sec network refresh time;
- RS485 interface with Modbus protocol;
- 8 Analog Outputs;
- Transmitters battery status and RF link quality information;
- Configurable over USB;
- DIN rail mounting.

REVISION HISTORY

VERSION

E01B	Segregation of thermometer and thermocouples input information in different tables; Addition of 868MHz frequency information; "Accuracy" table deleted; "Led Signage in connection and configuration" table added; In "Factory Default Settings" table, "Node ID" term updated to "Wireless transmitter ID"; In "Factory Default Settings" table, "Net ID" term updated to "Wireless network ID"; In "Certifications and approvals" table, addition of EN 300 228 and EN 300 440 certification;
E01C	Revision of Battery Life Time chart;

TEKON ELECTRONICS
a brand of Bresimar Automação S.A.

Quinta do Simão
3800-230 Aveiro
PORTUGAL

P.: +351 234 303 320
M.: +351 933 033 250
E.: sales@tekonelectronics.com

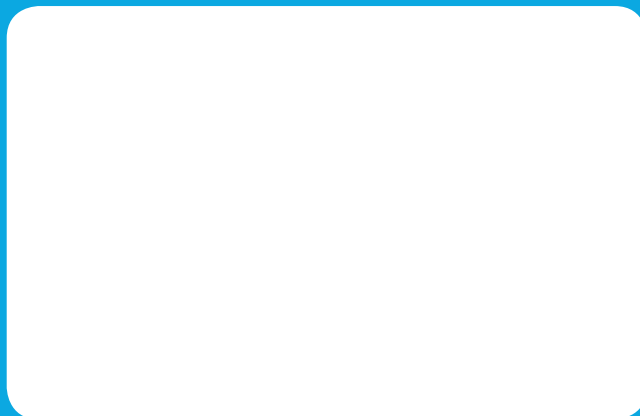

Cofinanciado por:



UNIÃO EUROPEIA
Fundo Europeu
de Desenvolvimento Regional