

THERMOCOUPLE TEMPERATURE TRANSMITTER THT201



The Tekon Electronics In Head Temperature Transmitters are specifically designed to meet the most rigorous requirements of operation in the industrial process environments. Due to their reduced dimensions they can be installed in the the DIN Form B sensor connection head in place of traditional terminal blocks.

The operating parameters like the sensor type, connection method, measuring range, output signal range or fault value can be configured using the THT201 user friendly free software Tekon Configurator.

Dimensions 45Ø x 23 mm

Weight Approx. 50g

Material Nylon 66

Protection Index IP40

KEY FEATURES

THERMOCOUPLE SENSOR INPUT

E, J, K, N, R, S, T

WIDE MEASUREMENT RANGE

4 TO 20 MA ANALOG OUTPUT

2 STATUS LEDS

HIGH MEASUREMENT ACCURACY

IN LINE LOOP CURRENT MEASURE PADS

NAMUR NE 43 FAULT DETECTION

CONFIGURABLE OVER PC

TEKON CONFIGURATOR SOFTWARE

DS_INHD.THT201_E01B

TECHNICAL SPECIFICATIONS

INPUT THERMOCOUPLES (TC)

Measured variable	Temperature
Sensor type	Thermocouples: E, J, K, N, R, S, T
Units	°C
Connection	Thermocouple (TC)
Sensor current diagnostic	<0,05 mA (50 uA)
Response time	<500 ms
Open-circuit monitoring	Always active (cannot be disabled)
Short-circuit monitoring	Not available
Cold junction compensation (CJC)	Integrated resistance thermometer
Measuring range	Configurable (see "Digital measurement accuracy" table)
Minimum measured span	50°C
Characteristic curve	Temperature-linear

OUTPUT

Output signal	4 to 20 mA
Power supply (Uaux)	9 to 30V DC
Max. load	$(U_{aux} - 9) / 0.022 \text{ A}$
Overrange	3 to 22 mA
Error signal (e.g. following sensor fault) (conforming to NE43)	Software configurable $\leq 3,6\text{mA}$ or $\geq 21\text{mA}$
Sample cycle	< 1s
Protection	Against reversed polarity; Surge protection

OPERATING ENVIRONMENT

Ambient temperature range	-20 to 80°C
Storage temperature range	-20 to 80°C
Relative humidity	$\leq 95\%$, without condensation

CASING

Material	Nylon 66
Weight	Approx. 50g
Dimensions	See "Dimensional drawings"
Cross section	2,5 mm ²
Protection type	IP40

CERTIFICATIONS AND APPROVALS

EN 61326	Electrical equipment for measurement, control and laboratory use. EMC requirements.
IEC 61000-4-2	Electrostatic discharge immunity test
IEC 61000-4-3	Radiated, radio-frequency, electromagnetic field immunity test
IEC 61000-4-4	Electrical fast transient/burst/immunity test
IEC61000-4-5	Surge immunity test

FACTORY DEFAULT SETTINGS	
Sensor	TEK
Measuring range	-200 to 1000°C
Fault current	NAMUR NE 43
Sensor offset	0°C
Sampling	0,0s

MEASURING ACCURACY

MEASUREMENT ACCURACY	
Reference conditions	
Auxiliary power	24V DC ± 1%
Ambient temperature	23°C
Warm up time	> 5min
Sensor type	TC K
Input span	[-200; 1000]°C
Accuracy [according to IEC 61298-2]	
Inaccuracy	-0,072% ; 0,038%
Max. error	-0,066%
Hysteresis	-0,018%
Non-repeatability	0,014%
Error in the analog output (digital/analog converter)	< 0,08% of span
Digital measuring errors	see "Digital measurement accuracy" table
Error due to internal cold junction	<0,5°C
Influence of ambient temperature	<0,3 μV / °C
EMC - immunity influence	< +/- 1,6% of span

DIGITAL MEASUREMENT ACCURACY

THERMOCOUPLES (TC)		
SENSOR	RANGE °C	DIGITAL ACCURACY °C
E	-200 to 1000	1
J	-210 to 1200	1
K	-230 to 1370	1
N	-200 to 1300	1
R	-50 to 1760	2
S	-50 to 1760	2
T	-200 to 400	1

The digital accuracy is the accuracy after the analog/digital conversion including linearization and calculation of the measured value. An additional error is generated in the output current 4 to 20mA as a result of the digital/analog conversation of 0.025% of the set span (digital-analog error). The total error under reference conditions at the analog output is the sum from the digital error and the digital-analog error (poss. with the addition of cold junction errors in the case of thermocouple measurements).

TECHNICAL DRAWINGS AND INFORMATION

DIMENSIONAL DRAWINGS & INSTALLATION DIAGRAM

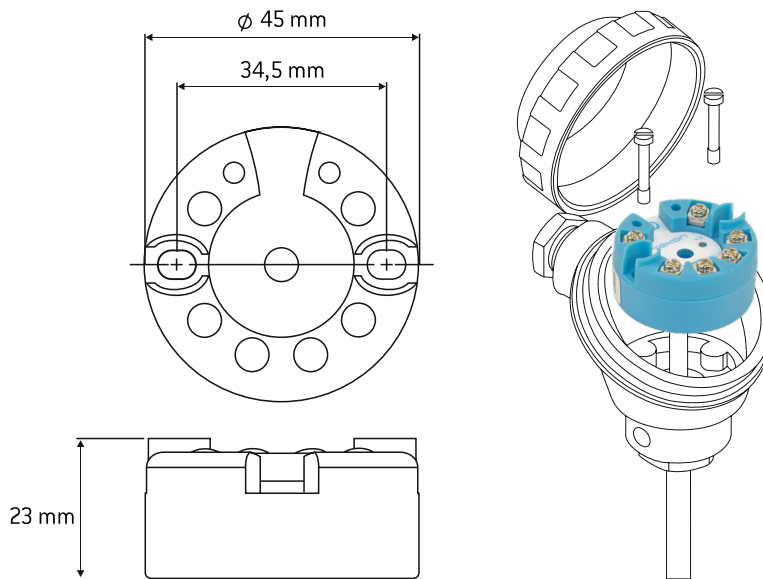

ELECTRICAL CONNECTIONS

POWER SUPPLY

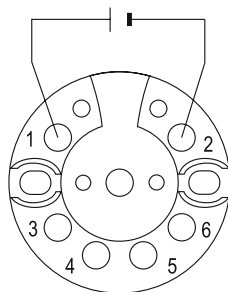

THERMOCOUPLE

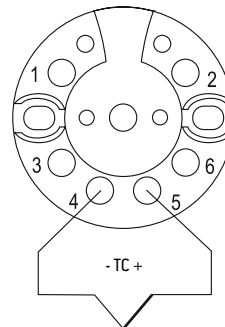

STATUS LEDs

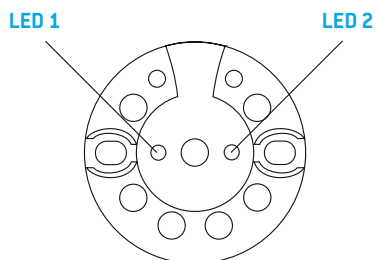

LED 1 (RED)	LED 2 (BLUE)	
OFF	ON	NORMAL MODE
FLASH	ON	SENSOR ERROR
OFF	BLINK	CONFIGURATION MODE

TEST POINTS

The test points may be used to measure the transmitter current consumption.
Please connect the test probes of multimeter with the DC current measurement option to the test points according to the following image.

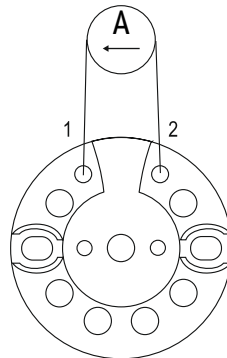

RELATED PRODUCTS



SARC 2 - USB CONFIGURATOR

REF.: PA132720310

Connection between a PC USB port and THT201 temperature head transmitter; USB powered for easy off-process configuration.

REVISION HISTORY

VERSION

E01B	In "Measurement Accuracy" table, "Sensor type", "Input span" and "Influence of ambiente temperature" information was added. "Factory Settings" renamed to "Factory Default Settings".
------	--

TEKON ELECTRONICS
a brand of Bresimar Automação S.A.

Quinta do Simão
3800-230 Aveiro
PORTUGAL

P.: +351 234 303 320
M.: +351 933 033 250
E.: sales@tekonelectronics.com



Cofinanciado por:



UNIÃO EUROPEIA
Fundo Europeu
de Desenvolvimento Regional