

PLUS PRODUCT FAMILY

PRODUCT MANUAL



PM_PLUS_ED1A

Table of contents

TECHNICAL SUPPORT AND ASSISTANCE	6
WARNINGS AND SAFETY	7
DISTRIBUTION	8
BEFORE BEGINNING THE INSTALLATION	8
CHAPTER 1 – PLUS WIRELESS SYSTEM OVERVIEW	9
INTRODUCTION	9
REFERENCES.....	9
CHAPTER 2 – PRODUCTS.....	10
PLUS TRANSMITTER TWP4AI	10
MECHANICAL INTERFACE AND DIMENSIONS	10
BLOCK DIAGRAM	11
LABELS	11
LEDS AND BUTTONS WORKFLOW.....	11
WIRING	12
ANALOG INPUTS	14
DIGITAL INPUT	15
CONFIGURATION	17
DIGITAL OUTPUTS.....	17
PLUS HEAD TRANSMITTER TWPH-1UT	19
MECHANICAL INTERFACE AND DIMENSIONS	19
BLOCK DIAGRAM	19
LABELS	20
LEDS AND BUTTONS WORKFLOW.....	20
DEVICE	21
SENSOR INPUT	21
WIRING	22
PLUS TRANSMITTER TWP-4AI4DI1UT	23
MECHANICAL INTERFACE AND DIMENSIONS	23
BLOCK DIAGRAM	24
LABELS	24
LEDS AND BUTTONS WORKFLOW.....	24
WIRING	25
DEVICE	27
SENSOR INPUT	28
ANALOG INPUTS	28
DIGITAL INPUTS	30

DIGITAL INPUTS BEHAVIOURS	32
DIGITAL OUTPUTS	33
PLUS REPEATER WRP001	36
MECHANICAL INTERFACE AND DIMENSIONS	36
BLOCK DIAGRAM	37
LABELS	37
LEDS AND BUTTONS WORKFLOW.....	37
WIRING	39
PLUS GATEWAY WGW420	40
MECHANICAL INTERFACE AND DIMENSIONS	40
BLOCK DIAGRAM	41
LABELS	41
LEDS WORKFLOW	41
WIRING	42
MODBUS	42
REMOTE DEVICES.....	43
TAB LAYOUT.....	43
COMMON DATA	44
TWP4AI	44
TWPH-1UT	44
TWP-4AI4DI1UT	44
ANALOG OUTPUTS.....	45
CHAPTER 3 – SYSTEM CONFIGURATION	47
OPERATION MODE.....	47
SITE SURVEY FEATURE	47
MODBUS MAPPING	48
HOLDING REGISTERS – TRANSMITTERS DATA	48
HOLDING REGISTERS – TRANSMITTERS DATA	48
COILS REGISTERS (GATEWAY).....	49
CONFIGURATION	49
APPENDIX.....	50
TECHNICAL SPECIFICATIONS	50
PLUS TRANSMITTER TWP4AI	50
PLUS HEAD TRANSMITTER TWPH-1UT	52
PLUS REPEATER WRP001	54
PLUS GATEWAY WGW420	55
PLUS TRANSMITTER TWP-4AI4DI1UT	56

Table of figures

Figure 1 - TWP4AI transmitter mechanical interface and dimensions	10
Figure 2 - Block diagram of TWP4AI transmitter	11
Figure 3 - Labels of TWP4AI transmitter	11
Figure 4 - TWP4AI PCB and connectors	13
Figure 5 - Analog inputs tab in Tekon Configurator software	14
Figure 6 - Analog inputs options in Tekon Configurator software.....	15
Figure 7 - Digital input tab in Tekon Configurator software	16
Figure 8 - Digital input options in Tekon Configurator software	16
Figure 9 - Digital outputs tab in Tekon Configurator software	17
Figure 10 – TWP4AI transmitter mechanical interface and dimensions	19
Figure 11 - Block diagram of TWP4AI transmitter	19
Figure 12 - Labels of TWP4AI transmitter	20
Figure 13 - Device tab in Tekon Configurator software.....	21
Figure 14 - Sensor input tab in Tekon Configurator software	22
Figure 15 - TWP4AI wire connections.....	22
Figure 16 – TWP-4AI4DI1UT transmitter mechanical interface and dimensions	23
Figure 17 - Block diagram of TWP-4AI4DI1UT	24
Figure 18 - Labels of TWP-4AI4DI1UT transmitter.....	24
Figure 19 - TWP-4AI4DI1UT PCB and connectors	26
Figure 20 - PT100 connection	26
Figure 21 - Thermocouple connection.....	26
Figure 22 - Device tab in Tekon Configurator software.....	27
Figure 23 - Sensor input tab in Tekon Configurator software	28
Figure 24 - Analog inputs tab in Tekon Configurator software	29
Figure 25 - Analog inputs options in Tekon Configurator software.....	29
Figure 26 - Digital inputs tab in Tekon Configurator software	30
Figure 27 - Digital input options in Tekon Configurator software	31
Figure 28 - Digital Inputs configuration and options	32
Figure 29 - Behaviour of digital input activation by Falling Edge	32
Figure 30 - Behaviour of digital input activation by Raising Edge.....	33
Figure 31 - Behaviour of digital input activation by Both	33
Figure 32 - Digital outputs tab in Tekon Configurator software.....	33
Figure 33 - Digital outputs tab in Tekon Configurator software.....	35
Figure 34 – WRP001 repeater mechanical interface and dimensions.....	36
Figure 35 - Block diagram of WRP001 repeater	37
Figure 36 - Labels of WRP001 repeater	37
Figure 37 - Configuration of WRP001 repeater at Tekon Configurator software.....	38
Figure 38 - PLUS Repeater WRP001 wiring.....	39
Figure 39 – WGW420 gateway mechanical interface and dimensions	40
Figure 40 - Block diagram of WGW420 gateway	41
Figure 41 - Labels of WGW420 gateway.....	41
Figure 42 - Connections in PLUS WGW420 gateway	42
Figure 43 - Tekon Configurator layout of remote devices tab.....	43
Figure 44 - TWP4AI layout of remote devices tab	43
Figure 45 - TWP4AI layout of remote devices tab	43
Figure 46 - Tekon Configurator layout of analog outputs tab	45
Figure 47 - Transmitter operation mode configuration in Tekon Configurator.....	47

Index of tables

Table 1 - TWP4AI LED behaviours.....	12
Table 2 - TWP4AI buttons behaviours	12
Table 3 - TWP4AI connectors and functionality	14
Table 4 - Description of the possible configurations for digital input trigger.....	16
Table 5 - Description of the digital output states related to the Link Lost Output.....	17
Table 6 - Description of Remote Control output features.....	18
Table 7 - Description of External Power output	18
Table 8 - TWPH-1UT LED behaviours.....	20
Table 9 - TWPH-1UT button behaviours.....	20
Table 10 - Description of Tekon Configurator "Device" tab of TWPH-1UT.....	21
Table 11 - TWP-4AI4DI1UT LEDs behaviours.....	25
Table 12 - TWP-4AI4DI1UT buttons behaviours.....	25
Table 13 - Description of TWP-4AI4DI1UT connections	27
Table 14 - Description of Tekon Configurator "Device" tab for TWP-4AI4DI1UT.....	28
Table 15 - Description of the possible configurations for digital input trigger.....	31
Table 16 - Description of the digital output states related to the Link Lost Output.....	34
Table 17 - Description of Remote Control output features.....	34
Table 18 - Description of External Power Control Output value	34
Table 19 - WRP001 LED behaviours.....	38
Table 20 - WRP001 buttons behaviours	38
Table 21 - GW420 LED behaviours.....	41
Table 22 - Modbus addresses.....	43
Table 23 - Description of each label from Tekon Configurator window.....	44
Table 24 - Description of each label from Tekon Configurator window (TWP4AI).....	44
Table 25 - Description of each label from Tekon Configurator window (TWPH-1UT).....	44
Table 26 - Description of each label from Tekon Configurator window (TWP-4AI4DI1UT)	45
Table 27 - Description of each label from Tekon Configurator window (Analog outputs).....	45
Table 28 - Modbus mapping - Holding Registers.....	48
Table 29 - Modbus mapping - Holding Registers - Analog output index	48
Table 30 - Coils address and description	49

COPYRIGHT

The documentation included with this product are copyrighted by Tekon Electronics. All rights are reserved. Tekon Electronics reserves the right to make improvements in the products described in this manual at any time without notice. No part of this manual may be reproduced, copied, translated, or transmitted in any form or by any means without a written permission of Tekon Electronics. The information provided in this manual is intended to be accurate and reliable. However, Tekon Electronics assumes no responsibility for its use, nor for any infringements of the rights of third parties that may result from its use.

PRODUCT WARRANTY

Tekon Electronics warrants the original purchaser that each of its products will be free from defects in materials and workmanship for **one year** from the date of purchase. If the unit malfunctions, it must be returned to the factory for evaluation. Upon examination by Tekon Electronics, if the unit is found to be defective, it will be repaired or replaced at no charge. This warranty is null if the unit shows evidence of having been tampered with or shows evidence of having been damaged as a result of excessive corrosion, current, heat, moisture or vibration; improper specification; misapplication; misuse or other operating conditions outside of Tekon Electronics control. Components in which wear is not warranted, include but are not limited to contact points.

Tekon Electronics warranty does not apply to defects resulting from any action of the purchaser, including but not limited to mishandling, operation outside of design limits, improper repair, or unauthorized modification. This warranty does not apply to any products that have been repaired or altered by persons other than repair personnel authorized by Tekon Electronics. Tekon Electronics assumes no liability or damage under the terms of this warranty because of such events.

Tekon Electronics assumes no responsibility for damage cause due to manufacturing and/or improper use/installation.

For out-of-warranty repairs, customers are billed according to the cost of replacement materials, service time, and freight. Please consult your dealer for more details.

Tekon Electronics reserves the right not to accept products for repair under and out of warranty if the following conditions are not met:

- If the product is not shipped with the serial number or other unique identifying element;
- If the product sent was not what the client intended;

TECHNICAL SUPPORT AND ASSISTANCE

Visit the Tekon Electronics web site at <https://www.tekonelectronics.com/en/support/> where you can find the latest updates about the product.

Contact your distributor or sales representative for technical support if you need additional assistance. Please have the following information ready before you call:

- Product name and serial number
- Description of your peripheral attachments
- Description of your configuration software (version, etc.)
- A complete description of the problem
- The exact wording of any error.

WARNINGS AND SAFETY

1. Read these safety instructions carefully.
2. Keep this User Manual for later reference.
3. Disconnect this equipment from power supply before cleaning. Use a damp cloth. Do not use liquid or spray detergents for cleaning.
4. Keep this equipment away from humidity.
5. Put this equipment on a reliable surface during installation. Dropping it or letting it fall may cause damage.
6. Make sure the voltage of the power source is correct before connecting the equipment to the power outlet.
7. Position the power cord so that people cannot step on it. Do not place anything over the power cord.
8. All cautions and warnings on the equipment should be noted.
9. If the equipment is not used for a long time, disconnect it from the power source to avoid damage by transient overvoltage.
10. Never put any liquid into an opening. This may cause fire or electrical shock.
11. If one of the following situations arises, get the equipment checked by service personnel:
 - The power cord or plug is damaged.
 - Liquid has penetrated the equipment.
 - The equipment has been exposed to moisture.
 - The equipment does not work well, or you cannot get it to work according to the user's manual.
 - The equipment has been dropped and damaged.
 - The equipment has obvious signs of breakage.
12. DO NOT LEAVE THIS EQUIPMENT IN AN ENVIRONMENT WHERE THE STORAGE TEMPERATURE MAY GO BELOW THE RECOMMENDED IN THE DATASHEET. THIS COULD DAMAGE THE EQUIPMENT.
13. This equipment is not entitled to protection against harmful interference and must not cause interference in duly authorized.



This symbol denotes especially important guidelines concerning the installation and operation of the device. Read any information regarding this symbol carefully. Not complying with the guidelines denoted by this symbol may cause an accident, damage or equipment destruction.



Waste Electrical and Electronic Equipment (WEEE) cannot be disposed of as common waste and such waste must be collected and disposed of separately. The equipment may contain materials that may have negative effects on human health and on the environment. In case of illegal disposal of electrical and electronic waste, the penalties are specified by local waste disposal legislation.

DISTRIBUTION

Tekon Electronics does not accept any responsibility for the incorrect and inappropriate distribution of its products, when carried out by authorized distributors or by customers who have purchased Tekon Electronics products and distribute them.

The distribution of Tekon Electronics products must ensure that the radio frequency of the product is accepted in the country of destination. Please check if the country you want to send the products to, allows the use of electronic devices with radio frequency emission equal to those emitted by the acquired products.

BEFORE BEGINNING THE INSTALLATION**Inspect the content**

Check if the received everything that is listed in the document that goes with your package. Inspect the container and equipment for signs of damage as soon as you receive the shipment. Note any evidence of rough handling in transit. Immediately report any damage to the shipping agent.

The carrier will not admit any damage claims unless all shipping material is saved for inspection. After examining and removing the contents, save the packing material and carton in the event reshipment is necessary.

CHAPTER 1 – PLUS WIRELESS SYSTEM OVERVIEW

INTRODUCTION

The PLUS wireless product family was developed to be a versatile solution and capable of being implemented in applications with different properties. Its easy implementation allows to integrate the solution with automation equipment (PLC, SCADA, PC or HMI) via Modbus RTU protocol. The variables common to several processes such as temperature, pH, humidity, conductivity, vibration, inclination, level and pressure are some of the examples of monitoring that the PLUS system can provide with the reading of 4..20mA or 0..10V signals through your analog inputs.

Despite the versatility of reading several variables, there are also products dedicated to exclusive temperature acquisition, such as the TWPH-1UT universal head transmitter.

All devices in the PLUS family use the specially developed protocol Tinymesh™ wireless communications. This protocol adds value to the network that ensures its reliability:

- self-forming;
- self-healing;
- self-optimizing;
- multipath;

The PLUS wireless system creates a robust and reliable network between the devices, whose coverage is reinforced by the PLUS WRP001 repeater or by the double functionality gathered by the transmitters, which can be configured to play transmitter and repeater roles simultaneously. PLUS family can be implemented as a solution in applications with direct or battery power supply.

The PLUS gateway WGW420 features a physical interface with 8 analog outputs that make it possible to connect devices for individual display of variables. The RS485 port allows the gateway to be integrated with other equipment to communicate with the Modbus protocol, thus playing the role of Modbus Slave.

All the products in the PLUS wireless family are configurable through the free software Tekon Configurator.

REFERENCES

You can check all the references of PLUS product family available so far for the market.

Reference	Designation
PA164510610	PLUS TWP-4AI4DI1UT WIRELESS TRANSMITTER 868 MHZ
PA164510620	PLUS TWP-4AI4DI1UT WIRELESS TRANSMITTER 915 MHZ
PA164510110	PLUS TWP4AI WIRELESS TRANSMITTER 868 MHZ
PA164510120	PLUS TWP4AI WIRELESS TRANSMITTER 915 MHZ
PA164510510	PLUS TWPH-1UT WIRELESS TRANSMITTER 868 MHZ
PA164510520	PLUS TWPH-1UT WIRELESS TRANSMITTER 915 MHZ
PA164510210	PLUS WGW420 WIRELESS GATEWAY 868 MHZ
PA164510220	PLUS WGW420 WIRELESS GATEWAY 915 MHZ
PA164510310	PLUS WRP001 WIRELESS REPEATER 868 MHZ
PA164510320	PLUS WRP001 WIRELESS REPEATER 915 MHZ

CHAPTER 2 – PRODUCTS

PLUS TRANSMITTER TWP4AI

MECHANICAL INTERFACE AND DIMENSIONS

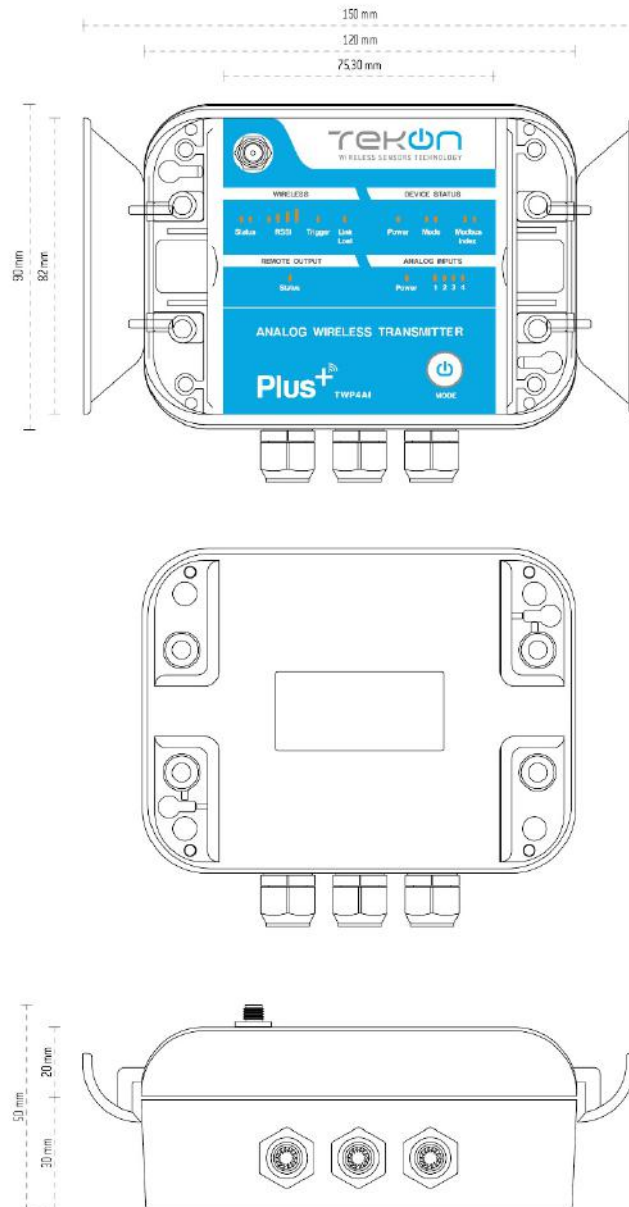

Figure 1 - TWP4AI transmitter mechanical interface and dimensions

BLOCK DIAGRAM

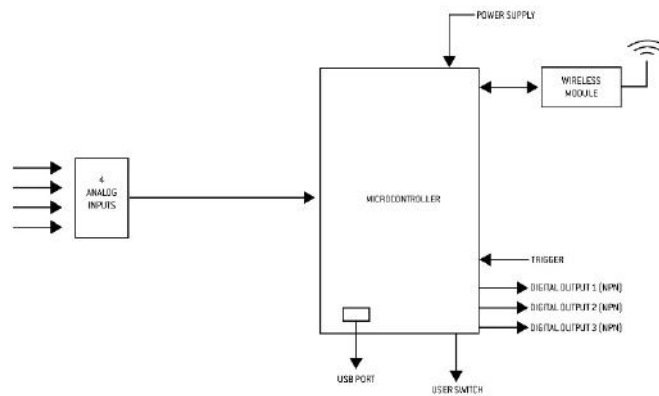

Figure 2 - Block diagram of TWP4AI transmitter

LABELS



Figure 3 - Labels of TWP4AI transmitter

LEDS AND BUTTONS WORKFLOW

LED	State	Transmitter Mode	Repeater Mode
Power (Device Status)	Network search	On while wireless connection is not established, and RF module does not go to Sleep mode	On
	Configuration	On	Idem
	Connected	Off	On
Mode (left)	Configuration	Flashes twice alternately with right LED	Idem
	Network search	Flashes every second	Idem
	Site survey	Flashes twice simultaneously with right LED	Idem
Mode (right)	Configuration	Flashes twice alternately with left LED	Idem
	Site survey	Flashes twice simultaneously with left LED	Idem
Modbus Index (left)	Boot	Flashes the number of times corresponding to the tens of the Modbus Index	Idem
Modbus Index (right)	Boot	After signalling the left Modbus Index LED, the number of Modbus Index units flashes a number of times	Idem
Status (wireless) (left) (controlled by RF module)	Network search	Flashes slowly – two seconds On and 2 seconds Off (Off 60 seconds after boot)	Idem (Never goes Off)
	Connected	Flashes according to the RSSI level (Off 60 seconds after boot)	Idem (Never goes Off)
	Configuration	On	Idem
	Site survey	On	Idem
Status	Network search	Off	Idem

(wireless) (right) (controlled by RF module)	Connected	Flashes five times if connected to the gateway and one time if connected to the repeater (Off 60 seconds after boot)	Idem (Never goes Off)
	Configuration	On	Idem
	Site survey	On	Idem
RSSI	Site survey	Number of LED's on according to the RSSI level of the packets received from the gateway or repeater. Flash simultaneously two times if no packet is received.	Idem
Trigger	Connected (active function)	On when it detects change of state; Remains On for the time defined in Warm Up Time and until the information is successfully transmitted;	Idem
Link Lost	Disconnected (active function)	On when there is a loss of connection to the network and the number of reconnection attempts is equal to the Cycles Number. On or Last State as defined in Startup State	Idem
	Connected (active function)	Off when recovering network connection	Idem
Status (remote switch)	-	Remotely defined in the corresponding Modbus register. On or Last State as defined in Startup State and Link Lost State.	Idem
Power (Analog Inputs)	Disconnected (active function)	On if Warm Up Time is greater than 0.	Idem
	Connected (active function)	On during the time preceding a communication and as defined in Warm Up Time.	Idem
1-2-3-4 (Analog Inputs)	-	Off.	On at the respective inputs configured in current or voltage
Internal	Error	Flashes x times according to the problems on the device under automatic diagnosis. Please contact the support to solve the problem.	Idem

Table 1 - TWP4AI LED behaviours

Button	State	Transmitter Mode	Repeater Mode
Mode	-	Press and hold for 3 seconds to activate the Site Survey mode	Idem
	Site survey	Press and hold for 3 seconds to deactivate the Site Survey mode and enters in network connection state	Idem
Internal	-	Press and hold for 5 seconds to reset the configurations.	Idem

Table 2 - TWP4AI buttons behaviours

WIRING

In the next image you can check where the wire connections are made and which connectors to use. Please use the connectors according to the indications.



The connectors marked as “Not used” should not be used in any circumstances in this transmitter.

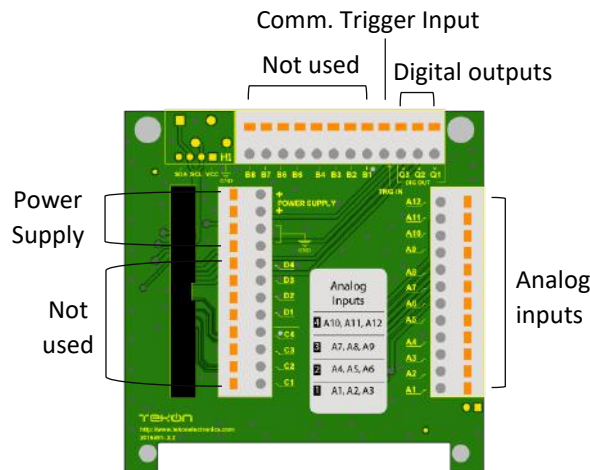

Figure 4 - TWP4AI PCB and connectors

The next table is a detailed description of each connector and its functionality.



Please pay attention to the different configurations of the analog inputs in case of current or voltage mode

PIN	Functionality		
		Current Mode	Voltage Mode
A1	Analog Input 1	I (mA)	V+
A2		I (mA)	NC
A3		GND	GND
A4	Analog Input 2	I (mA)	V+
A5		I (mA)	NC
A6		GND	GND
A7	Analog Input 3	I (mA)	V+
A8		I (mA)	NC
A9		GND	GND
A10	Analog Input 4	I (mA)	V+
A11		I (mA)	NC
A12		GND	GND
B1	Not used		
B2	Not used		
B3	Not used		
B4	Not used		
B5	Not used		
B6	Not used		
B7	Not used		
B8	Not used		
C1	Not used		
C2	Not used		
C3	Not used		
C4	Not used		
D1	Not used		

D2	Not used		
D3	Not used		
D4	Not used		
TRIG IN	Digital Trigger Input		
Q1	Digital Remote Switch Output		
Q2	Digital External Power Control		
Q3	Digital RF Link Lost Output		

Table 3 - TWP4AI connectors and functionality

ANALOG INPUTS

The analog inputs of the TWP4AI transmitter are the connection points with the sensors that measure the desired variables. The 4 analog inputs are configured independently, thus allowing to define whether the electrical signal that arrives at each of the inputs is of the current or voltage type. During the transmitter configuration mode, in the “Tekon Configurator” software, a dedicated tab is displayed to the configuration of the analog inputs.

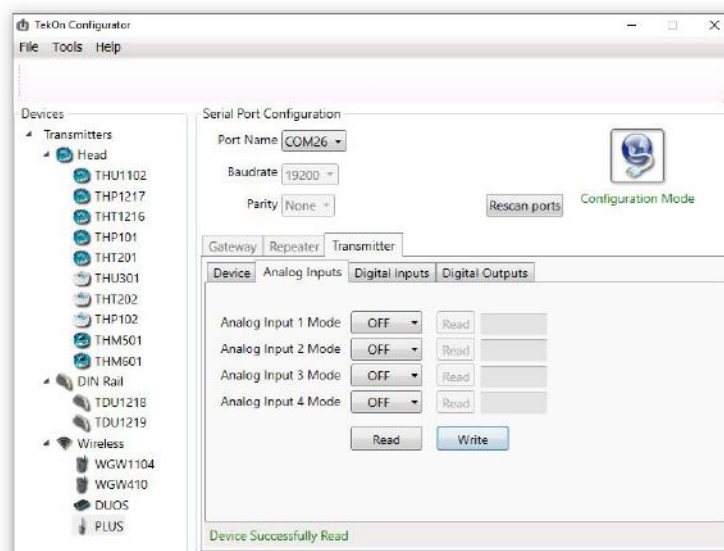

Figure 5 - Analog inputs tab in Tekon Configurator software

1. Configuration

Expand the checkbox for the analog input you want to configure.

Select the type of signal that will be registered by the input (current or voltage).

NOTE: by default, all analog inputs are off.

After choosing the type of signal, click on “Write” to set and save the changes.

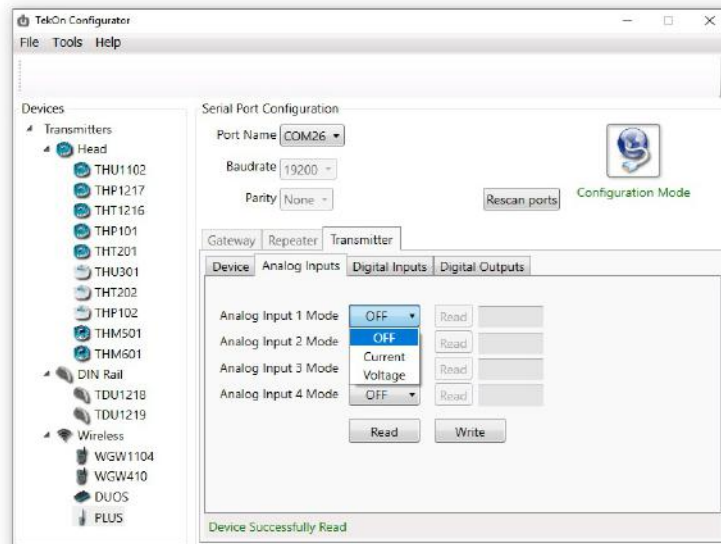

Figure 6 - Analog inputs options in Tekon Configurator software

2. Analog inputs values

You can read the analog inputs at the configuration with the intention of checking if the signal is being received correctly.

After saving the changes, click on “Read” to check the values that are being registered.



If the displayed value is “65535”, it is a sign that the previous state of the analog input was “OFF” and that the change to current or voltage was not saved. Please repeat the procedure.

The possibility of checking the signals received at the analog inputs at the time of configuration, allows you to optimize the installation process and thus you can now proceed to the installation of the equipment with the connections previously verified.

DIGITAL INPUT

The digital input of the TWP4AI transmitter acts as a trigger to an instant communication by the transmitter. This input is used to control operations that have only two operating states. The value returned for the digital input is binary – 0 or 1.

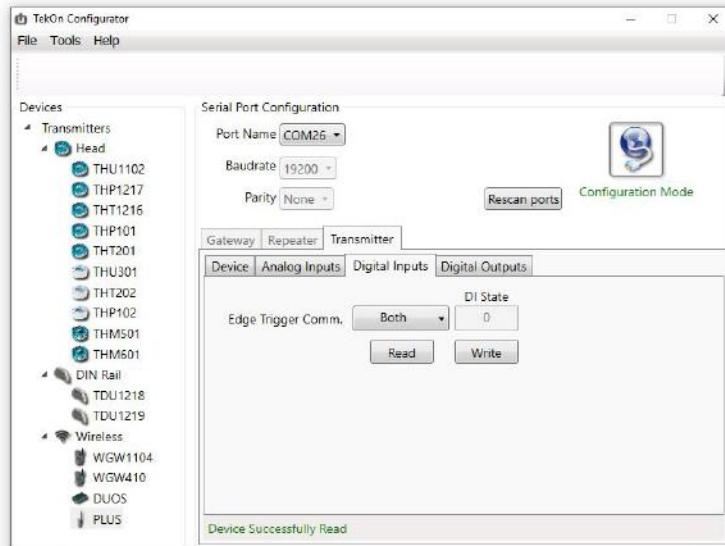

Figure 7 - Digital input tab in Tekon Configurator software

The different operation modes of the digital input allow the user to define under what circumstances we want a communication triggered by an event monitored by the equipment connected to this input.

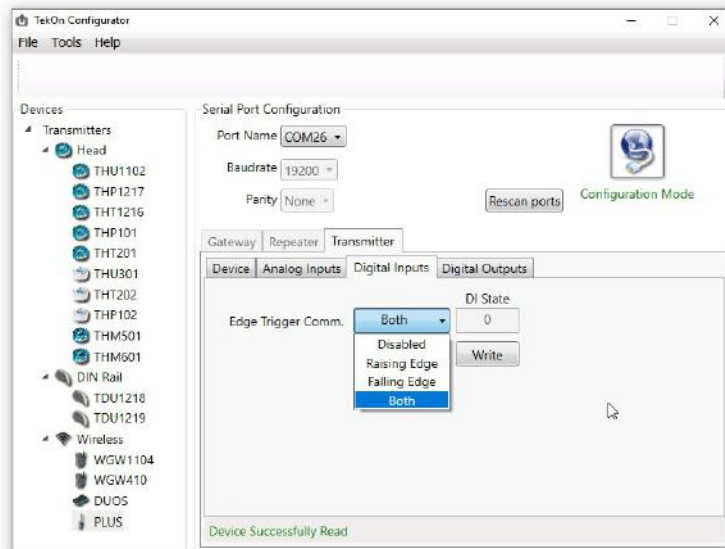

Figure 8 - Digital input options in Tekon Configurator software

State	Description
Disabled	Digital input is off.
Raising Edge	Communicates when the state goes from 0 to 1.
Falling Edge	Communicates when the state goes from 1 to 0.
Both	Communicates whenever states change.

Table 4 - Description of the possible configurations for digital input trigger

CONFIGURATION

Select the digital input operation mode.

Click on “Write” to set and save the changes.

Click on “Read” to check the state of the digital input trigger.

DIGITAL OUTPUTS

In the “Digital Outputs” tab of the Tekon Configurator software, the user can configure the options of the digital outputs that control signal loss, remote control status and warm-up time for devices to communicate with the gateway.

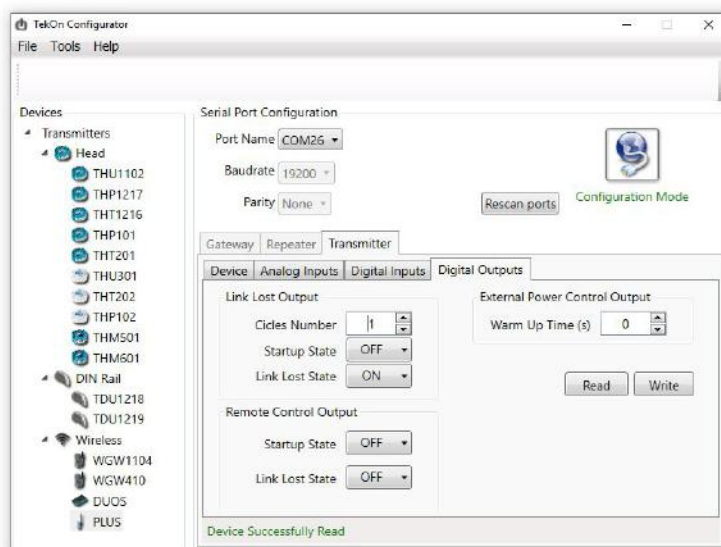

Figure 9 - Digital outputs tab in Tekon Configurator software

Link Lost Output

In this digital output it is possible to configure under which circumstances the loss of the connection signal to the gateway will activate the LED present on the transmitter front panel. This output is featured by three points, described in the following table.

Feature	Value / State	Description
Cycles Number	1 to 10	Number of cycles of the communication period to activate the link lost LED.
Startup State	OFF	Initial state of the digital output when the device is powered on.
	ON	
	Last State	
Link Lost State	ON	Digital output status when the transmitter link to the gateway is lost.
	OFF	

Table 5 - Description of the digital output states related to the Link Lost Output

Remote Control Output

Feature	Value / State	Description
Startup State	OFF	Initial state of the digital output when the device is powered on.
	ON	
	Last State	
Link Lost State	ON	Digital output status when the transmitter link to the gateway is lost.
	OFF	
	Last State	

Table 6 - Description of Remote Control output features

External Power Control Output

The digital output for external power allows to define the time before the moment of communication when the transmitter leaves Sleep Mode to prepare to perform the communication.

Feature	Value / State	Description
Warm Up Time(s)	0 to 255	Time in seconds to enable external power to devices before the communications to the gateway.

Table 7 - Description of External Power output



If the “Warm Up Time” defined is longer than the communication period, this pin will be always active.

Configuration

Select the required options or define the values in each field.

Click on “Write” to set and save the changes.

PLUS HEAD TRANSMITTER TWPH-1UT
MECHANICAL INTERFACE AND DIMENSIONS

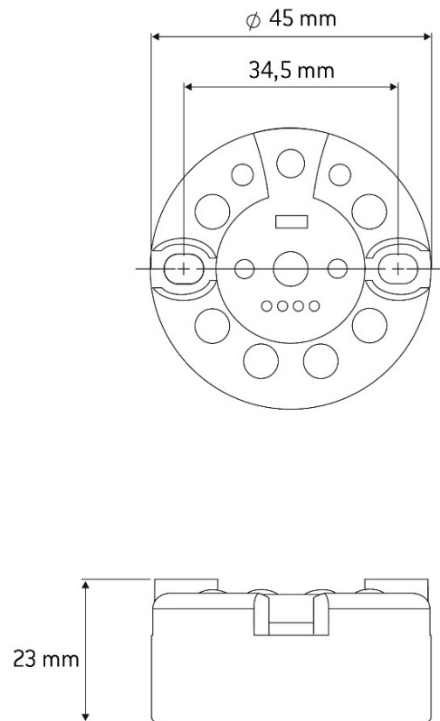

Figure 10 – TWPH-1UT transmitter mechanical interface and dimensions

BLOCK DIAGRAM

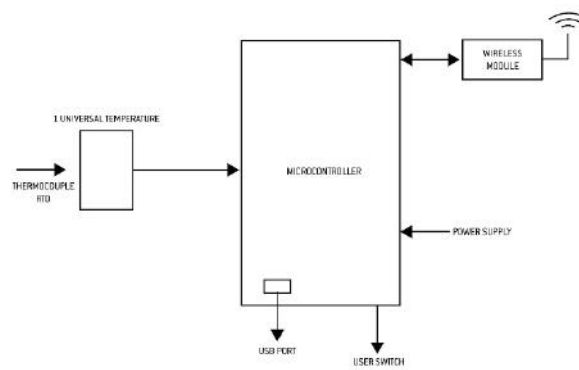

Figure 11 - Block diagram of TWPH-1UT transmitter

LABELS



Figure 12 - Labels of TWPH-1UT transmitter

LEDS AND BUTTONS WORKFLOW

LED		State	Transmitter Mode	Repeater Mode
Green (left)	Red (right)	Configuration	On	Idem
		Try connection	Red LED blinks	Idem
		Connected	Red and Green LED flashes alternately. Goes off after 1 minute.	Does not go off
		Sleep / Normal	Off	Does not go off
		Disconnected (retry connection)	Red LED blinks over 1 minute	Idem
Blue	Configuration	The 4 blue LEDs flashes every second.	Idem	
	Try connection	Off	Idem	
	Connected	Off	Idem	
	Sleep / Normal	Off	Idem	
	Disconnected (retry connection)	Off	Idem	
	Site survey	The LED's will stay on according to the RSSI detected.	Idem	

Table 8 - TWPH-1UT LED behaviours

Button	State	Transmitter Mode	Repeater Mode
Test	Site survey	Press and hold for 3 seconds to activate the Site Survey mode. Press and hold for 3 seconds to deactivate the Site Survey mode.	Idem
	Load Default Settings	Press and hold for 10 seconds to reset the transmitter configurations. The transmitter will be configured with the default settings.	Idem

Table 9 - TWPH-1UT button behaviours

DEVICE

The configuration of the elements necessary for the communication of TWPB-1UT transmitter within the gateway network is done in the Device tab, in the Tekon Configurator software.

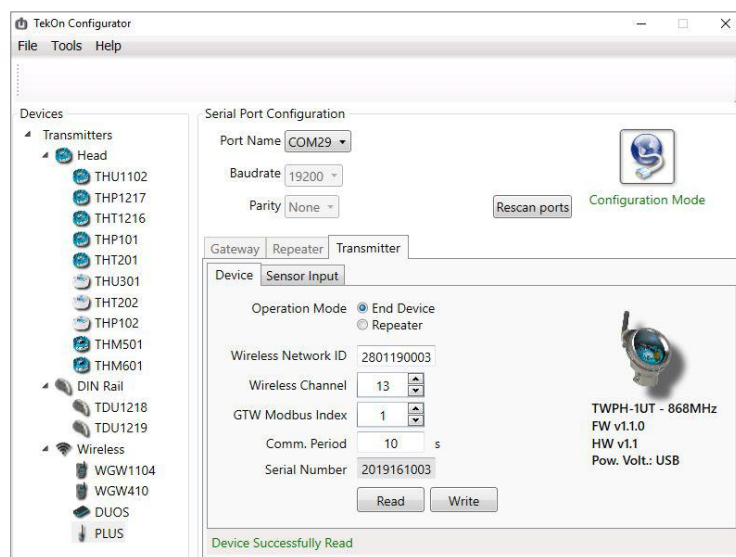

Figure 13 - Device tab in Tekon Configurator software

The displayed fields can be configured with exception of the “Serial Number” value.

Field	Description
Operation Mode	Operate as End Device or Repeater and End Device. (*)
Wireless Network ID	Wireless network id must match with the gateway value.
Wireless Channel	Wireless channel must match with the gateway value.
GTW Modbus Index	Modbus index from 1 to 55 to identify the transmitter.
Comm. Period	Communication period of the transmitter.

(*) See the topic “**Operation Mode**” to know more about this feature.

Table 10 - Description of Tekon Configurator “Device” tab of TWPB-1UT

SENSOR INPUT

The TWPB-1UT transmitter has an universal temperature input that can support PT100-type temperature sensors or thermocouples. The configuration of the sensor connected to the transmitter is done through the Tekon Configurator software, in the Sensor Input tab.

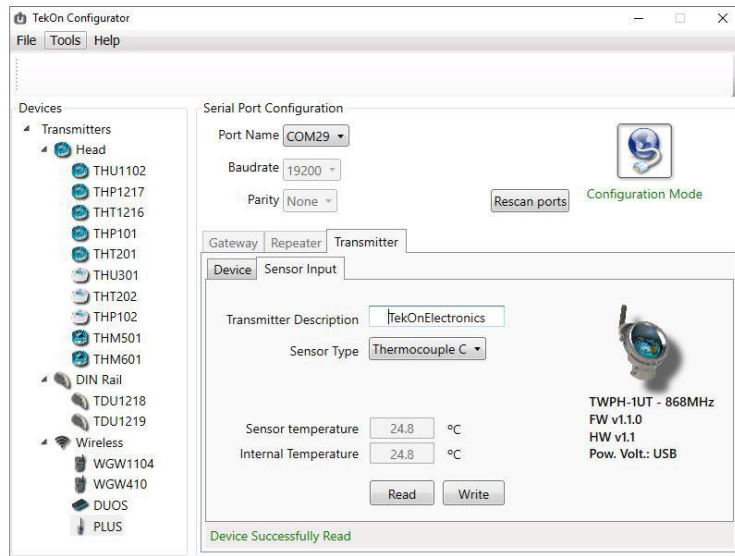

Figure 14 - Sensor input tab in Tekon Configurator software



In case of an error in the sensor input, the value “65535” is displayed in the “Sensor temperature” field.

WIRING

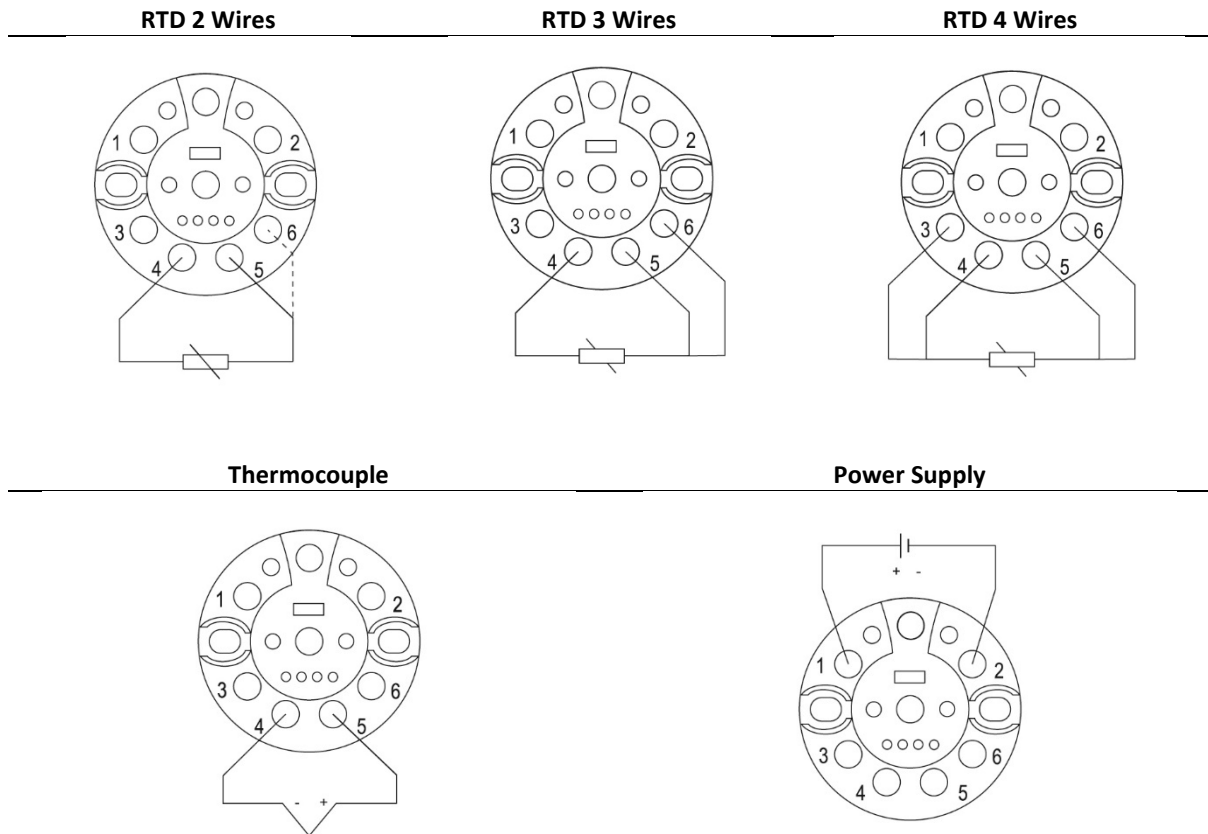

Figure 15 - TWPB-1UT wire connections

PLUS TRANSMITTER TWP-4AI4DI1UT

MECHANICAL INTERFACE AND DIMENSIONS

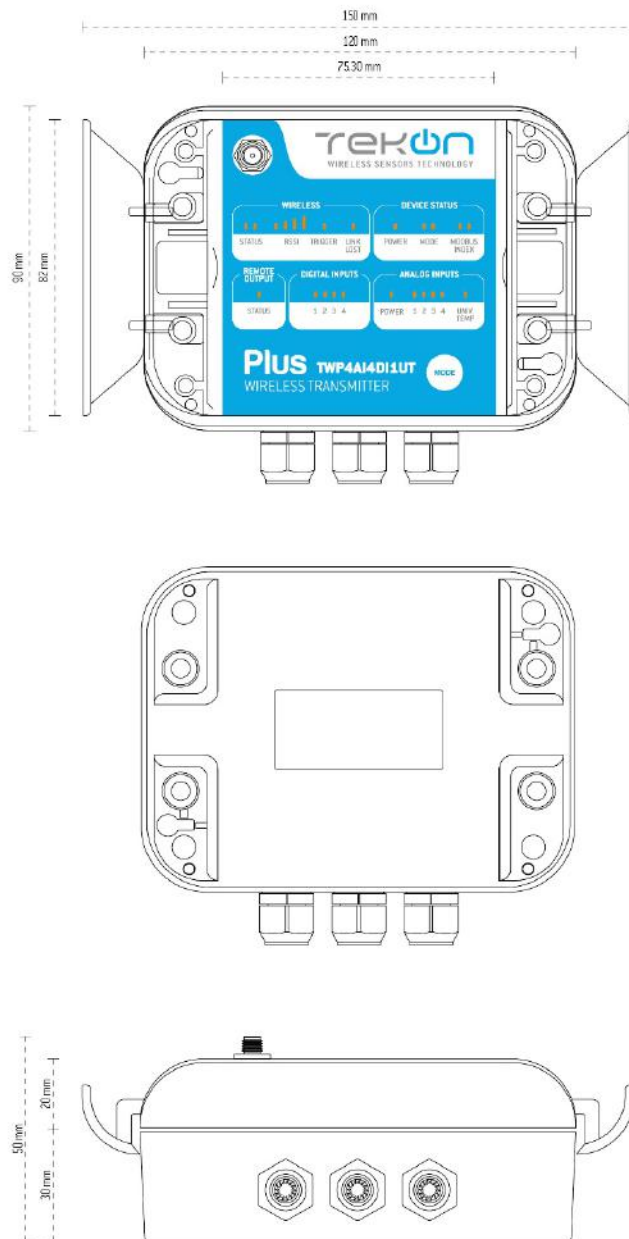

Figure 16 – TWP-4AI4DI1UT transmitter mechanical interface and dimensions

BLOCK DIAGRAM

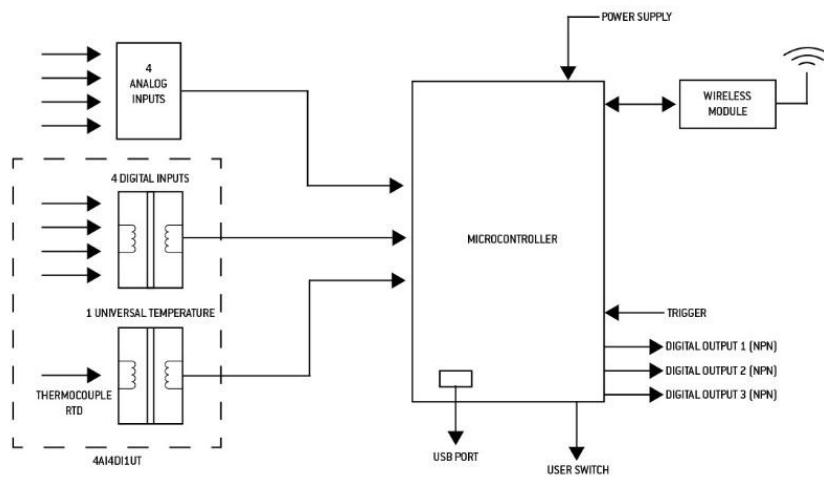

Figure 17 - Block diagram of TWP-4AI4DI1UT

LABELS



Figure 18 - Labels of TWP-4AI4DI1UT transmitter

LEDS AND BUTTONS WORKFLOW

LED	State	Transmitter Mode	Repeater Mode
Power (Device Status)	Network search	On while wireless connection is not established, and RF module does not go to Sleep mode	On
	Configuration	On	Idem
	Connected	Off	On
Mode (Device Status) (left)	Configuration	Flashes twice alternately with right LED	Idem
	Network search	Flashes every second	Idem
	Site survey	Flashes twice simultaneously with right LED	Idem
Mode (Device Status) (right)	Configuration	Flashes twice alternately with left LED	Idem
	Site survey	Flashes twice simultaneously with left LED	Idem
Modbus Index (Device Status) (left)	Boot	Flashes the number of times corresponding to the tens of the Modbus Index	Idem
Modbus Index (Device Status) (right)	Boot	After signalling the left Modbus Index LED, the number of Modbus Index units flashes a number of times	Idem
Status (Wireless) (left)	Network search	Flashes slowly – two seconds On and 2 seconds Off (Off 60 seconds after boot)	Idem (Never goes Off)
	Connected	Flashes according to the RSSI level (Off 60 seconds after boot)	Idem (Never goes Off)
	Configuration	On	Idem

(controlled by RF module)	Site survey	On	Idem
Status (Wireless) (right) (controlled by RF module)	Network search	Off	Idem
	Connected	Flashes five times if connected to the gateway and one time if connected to the repeater (Off 60 seconds after boot)	Idem (Never goes Off)
	Configuration	On	Idem
	Site survey	On	Idem
RSSI (Wireless)	Site survey	Number of LED's on according to the RSSI level of the packets received from the gateway or repeater. Flash simultaneously two times if no packet is received.	Idem
Trigger (Wireless)	Connected (active function)	On when it detects change of state; Remains On for the time defined in Warm Up Time and until the information is successfully transmitted;	Idem
Link Lost (Wireless)	Disconnected (active function)	On when there is a loss of connection to the network and the number of reconnection attempts is equal to the Cycles Number. On or Last State as defined in Startup State	Idem
	Connected (active function)	Off when recovering network connection	Idem
Status (Remote Output)	-	Remotely defined in the corresponding Modbus register. On or Last State as defined in Startup State and Link Lost State.	Idem
Power (Analog Inputs)	Disconnected (active function)	On if Warm Up Time is greater than 0.	Idem
	Connected (active function)	On during the time preceding a communication and as defined in Warm Up Time.	Idem
1-2-3-4 (Analog Inputs)	-	Off.	On at the respective inputs configured in current or voltage
Univ. Temp. (Analog Inputs)		Measured value inside the temperature range – Green LED Out of range, sensor error or incorret type of sensor - Red LED	Idem
1-2-3-4 (Digital Inputs)	State	Ative - On	Idem
Internal	Error	Flashes x times according to the problems on the device under automatic diagnosis. Please contact the support to solve the problem.	Idem

Table 11 - TWP-4AI4DI1UT LEDs behaviours

Button	State	Transmitter Mode	Repeater Mode
Mode	-	Press and hold for 3 seconds to activate the Site Survey mode	Idem
	Site survey	Press and hold for 3 seconds to deactivate the Site Survey mode and enters in network connection state	Idem
	LEDs in use	Click the button and LEDs will light up for 3 minutes.	
Internal	-	Press and hold for 5 seconds to reset the configurations.	Idem

Table 12 - TWP-4AI4DI1UT buttons behaviours

WIRING

In the next image you can check where the wire connections are made and which connectors to use. Please use the connectors according to the indications.



The connectors marked as “Not used” should not be used in any circumstances in this transmitter.

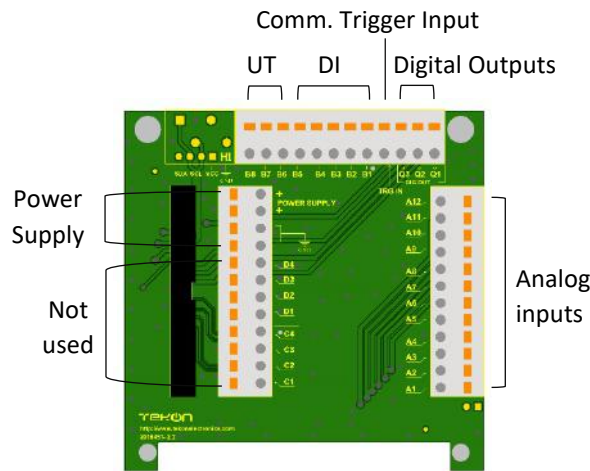

Figure 19 - TWP-4AI4DI1UT PCB and connectors

Universal Temperature Input

The universal temperature input allows to user to connect PT100 or thermocouple type sensors. The installation must respect the polarity of the inputs represented in the following images.

PT100

Thermocouple

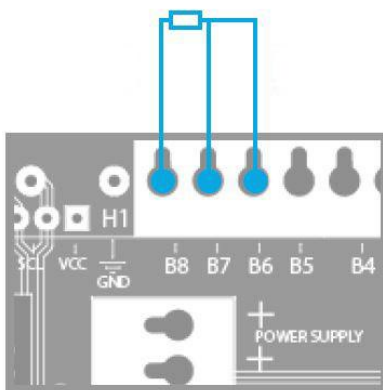

Figure 20 - PT100 connection

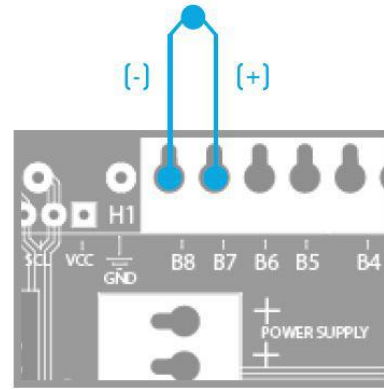

Figure 21 - Thermocouple connection

The next table represent all the available pins of TWP-4AI4DI1UT transmitter.

PIN	Functionality	
	Current Mode	Voltage Mode
A1	I (mA)	V+
A2	I (mA)	NC
A3	GND	GND
A4	I (mA)	V+
A5	I (mA)	NC
A6	GND	GND

A7	Analog Input 3	I (mA)	V+
A8		I (mA)	NC
A9		GND	GND
A10	Analog Input 4	I (mA)	V+
A11		I (mA)	NC
A12		GND	GND
B1	Digital Input 1		
B2	Digital Input 2		
B3	Digital Input 3		
B4	Digital Input 4		
B5	Digital Input Commons (GND)		
B6	Universal Temperature Input		
B7			
B8			
C1	Not used		
C2	Not used		
C3	Not used		
C4	Not used		
D1	Not used		
D2	Not used		
D3	Not used		
D4	Not used		
TRIG IN	Digital Trigger Input		
Q1	Digital Remote Switch Output		
Q2	Digital External Power Control		
Q3	Digital RF Link Lost Output		

Table 13 - Description of TWP-4AI4DI1UT connections

DEVICE

The configuration of the elements necessary for the communication of TWP-4AI4DI1UT transmitter within the gateway network is done in the Device tab, in the Tekon Configurator software.

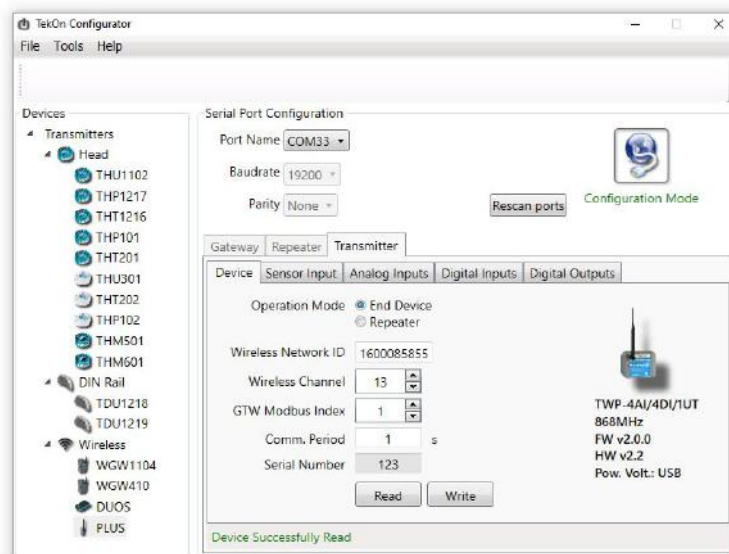

Figure 22 - Device tab in Tekon Configurator software

Field	Description
Operation Mode	Operate as End Device or Repeater and End Device. (*)
Wireless Network ID	Wireless network id must match with the gateway value.
Wireless Channel	Wireless channel must match with the gateway value.
GTW Modbus Index	Modbus index from 1 to 55 to identify the transmitter.
Comm. Period	Communication period of the transmitter.

(*) See the topic “**Operation Mode**” to know more about this feature.

Table 14 - Description of Tekon Configurator "Device" tab for TWP-4AI4DI1UT

SENSOR INPUT

The TWP-4AI4DI1UT transmitter has an universal temperature input that can support PT100-type temperature sensors or thermocouples. The configuration of the sensor connected to the transmitter is done through the Tekon Configurator software, in the Sensor Input tab.

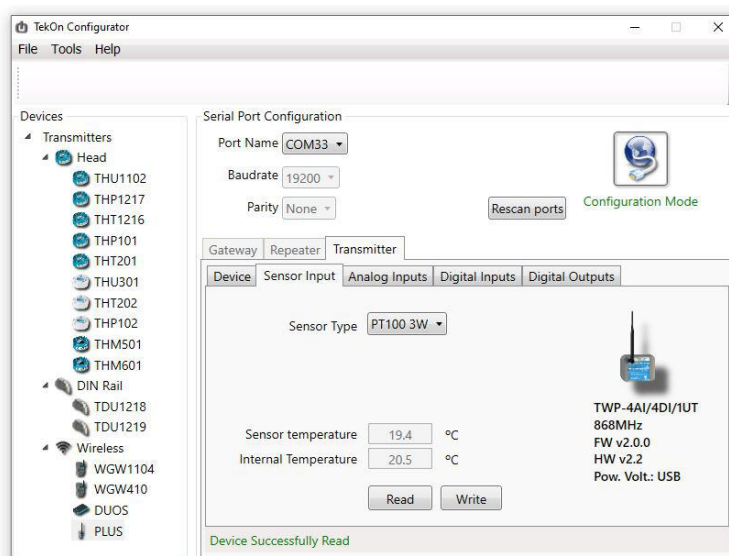

Figure 23 - Sensor input tab in Tekon Configurator software



In case of an error in the sensor input, the value “65535” is displayed in the “Sensor temperature” field.

ANALOG INPUTS

The analog inputs of the TWP-4AI4DI1UT transmitter are the connection points with the sensors that measure the desired variables. The 4 analog inputs are configured independently, thus allowing to define whether the electrical signal that arrives at each of the inputs is of the current or voltage type. During the transmitter

configuration mode, in the “Tekon Configurator” software, a dedicated tab is displayed to the configuration of the analog inputs.

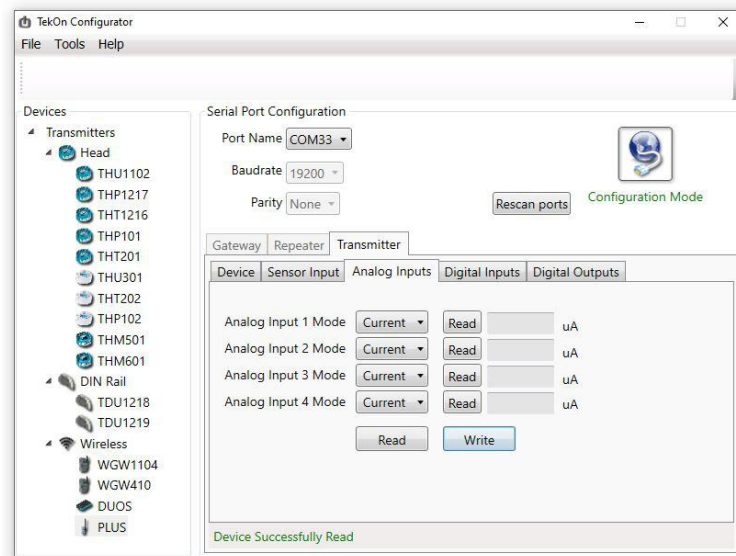

Figure 24 - Analog inputs tab in Tekon Configurator software

1. Configuration

Expand the checkbox for the analog input you want to configure.

Select the type of signal that will be registered by the input (current or voltage).

NOTE: by default, all analog inputs are off.

After choosing the type of signal, click on “Write” to set and save the changes.

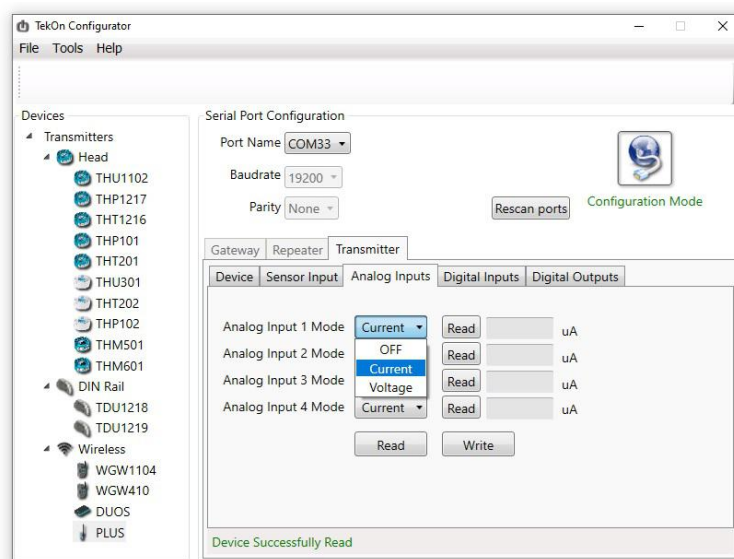

Figure 25 - Analog inputs options in Tekon Configurator software

1. Analog inputs values

You can read the analog inputs at the configuration with the intention of checking if the signal is being received correctly.

After saving the changes, click on “Read” to check the values that are being registered.



If the displayed value is “65535”, it is a sign that the previous state of the analog input was “OFF” and that the change to current or voltage was not saved. Please repeat the procedure.

The possibility of checking the signals received at the analog inputs at the time of configuration, allows you to optimize the installation process and thus you can now proceed to the installation of the equipment with the connections previously verified.

DIGITAL INPUTS

The digital input communication trigger of the TWP-4AI4DI1UT transmitter acts as a trigger to an instant communication by the transmitter. This input is used to control operations that have only two operating states. The value returned for the digital input is binary – 0 or 1.

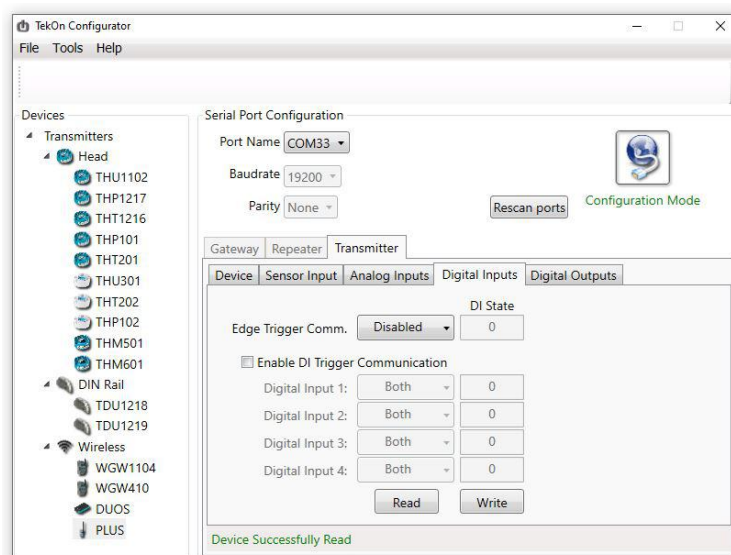

Figure 26 - Digital inputs tab in Tekon Configurator software

The different operation modes of the digital input allow the user to define under what circumstances we want a communication triggered by an event monitored by the equipment connected to this input.

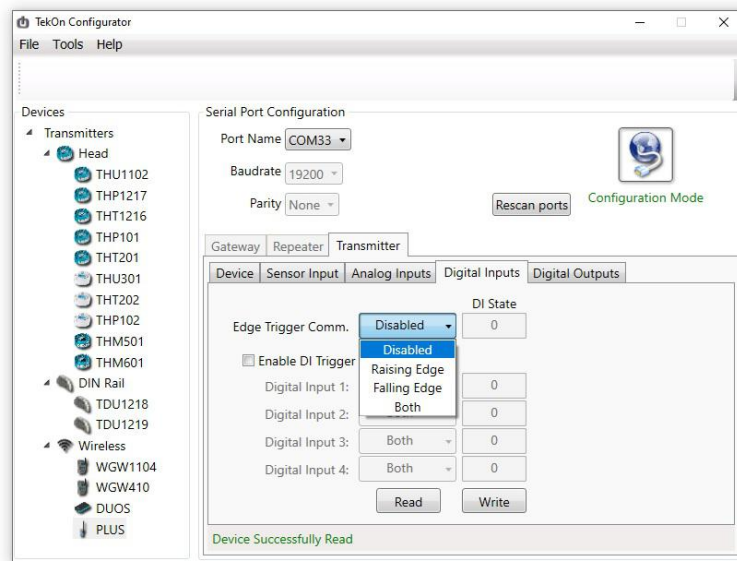

Figure 27 - Digital input options in Tekon Configurator software

State	Description
Disabled	Digital input is off.
Raising Edge	Communicates when the state goes from 0 to 1.
Falling Edge	Communicates when the state goes from 1 to 0.
Both	Communicates whenever states change.

Table 15 - Description of the possible configurations for digital input trigger

Configuration

Select the digital input operation mode.

Click on “Write” to set and save the changes.

Click on “Read” to check the state of the digital input trigger.

The four digital inputs of TWP-4AI4DI1UT transmitter are disable by default. To enable it and configure it, please click on the checkbox “Enable DI Trigger Communication”.

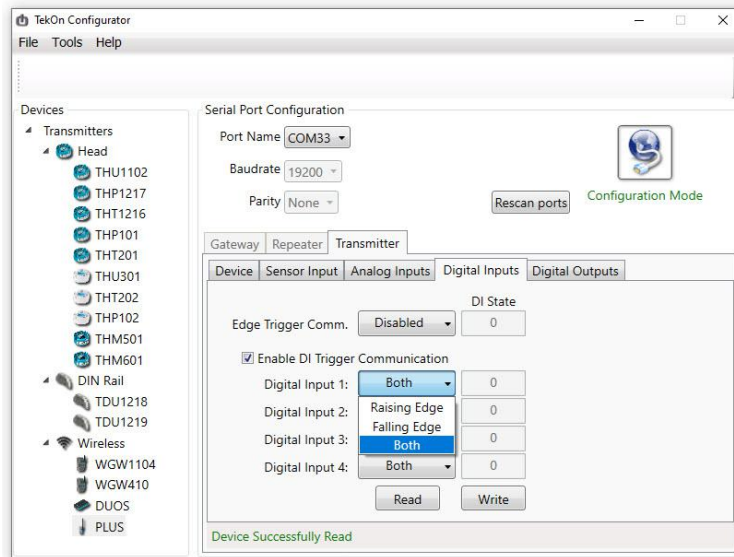

Figure 28 - Digital Inputs configuration and options

The options of each digital input are now available for configuration.

Configuration

Select the digital input transition trigger.

Click on “Write” to set and save the changes.

Click on “Read” to check the state of the digital input.

DIGITAL INPUTS BEHAVIOURS

Each state of the digital inputs has different behaviours along the time. The report of the digital input state occurs in distinct ways. The following three images illustrate the behaviour of each event trigger.

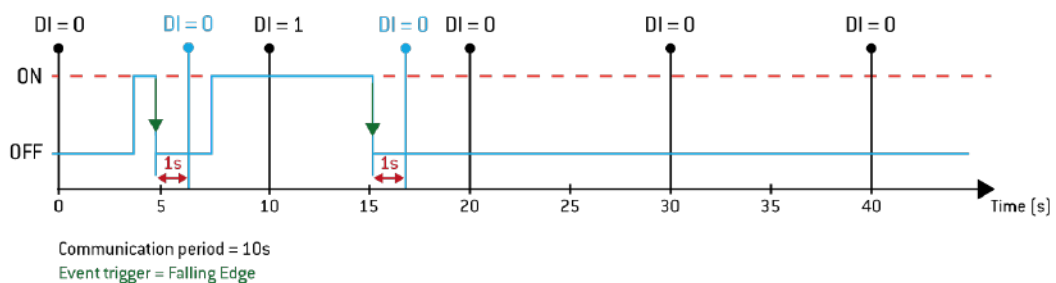

Figure 29 - Behaviour of digital input activation by Falling Edge

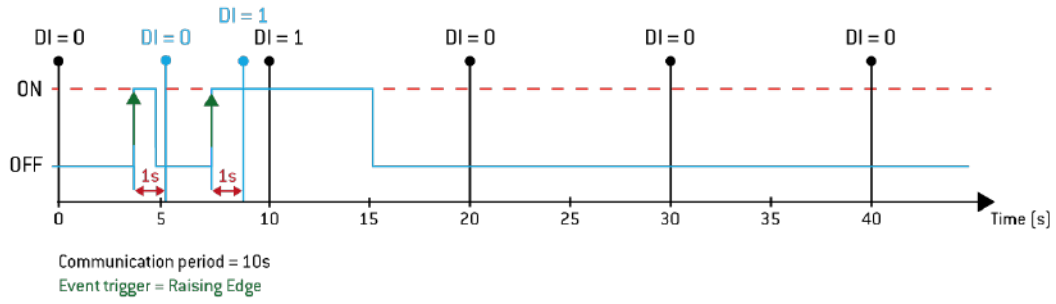

Figure 30 - Behaviour of digital input activation by Raising Edge

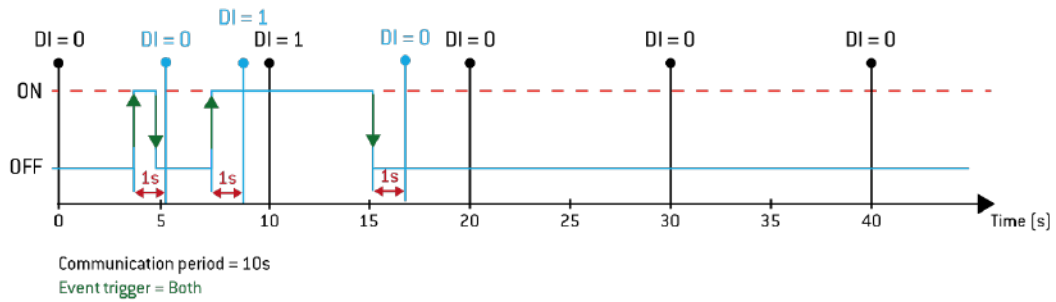

Figure 31 - Behaviour of digital input activation by Both

DIGITAL OUTPUTS

In the “Digital Outputs” tab of the Tekon Configurator software, the user can configure the options of the digital outputs that control signal loss, remote control status and warm-up time for devices to communicate with the gateway.

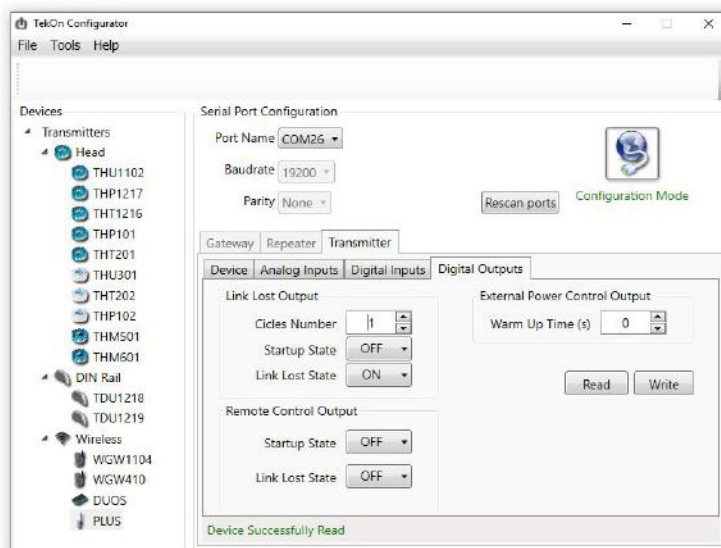

Figure 32 - Digital outputs tab in Tekon Configurator software

Link Lost Output

In this digital output it is possible to configure under which circumstances the loss of the connection signal to the gateway will activate the LED present on the transmitter front panel. This output is featured by three points, described in the following table.

Feature	Value / State	Description
Cicles Number	1 to 10	Number of cycles of the communication period to activate the link lost LED.
Startup State	OFF	Initial state of the digital output when the device is powered on.
	ON	
	Last State	
Link Lost State	ON	Digital output status when the transmitter link to the gateway is lost.
	OFF	

Table 16 - Description of the digital output states related to the Link Lost Output

Remote Control Output

Feature	Value / State	Description
Startup State	OFF	Initial state of the digital output when the device is powered on.
	ON	
	Last State	
Link Lost State	ON	Digital output status when the transmitter link to the gateway is lost.
	OFF	
	Last State	

Table 17 - Description of Remote Control output features

External Power Control Output

The digital output for external power allows to define the time before the moment of acquisition and communication when the transmitter leaves Sleep Mode to prepare to perform the communication.

Feature	Value / State	Description
Warm Up Time(s)	0 to 255	Time in seconds to enable external power to devices before the communications to the gateway.

Table 18 - Description of External Power Control Output value



If the “Warm Up Time” defined is longer than the communication period, this pin will be always active.

Configuration

Select the required options or define the values in each field.

Click on “Write” to set and save the changes.

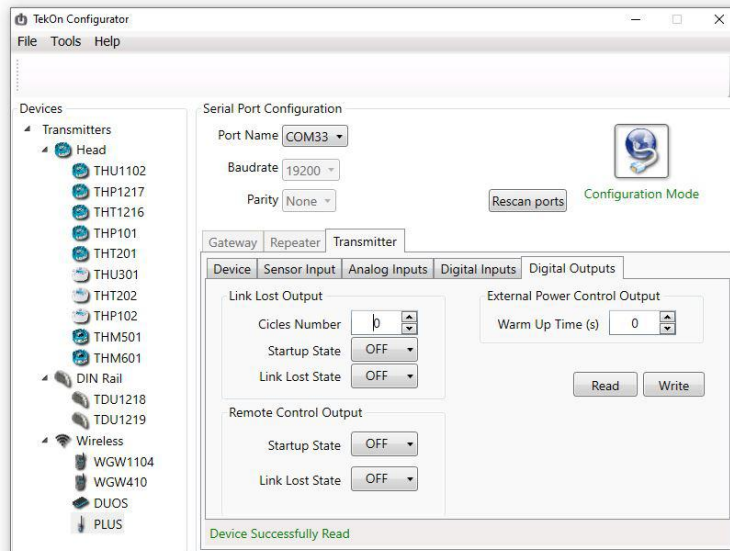

Figure 33 - Digital outputs tab in Tekon Configurator software

PLUS REPEATER WRP001

MECHANICAL INTERFACE AND DIMENSIONS

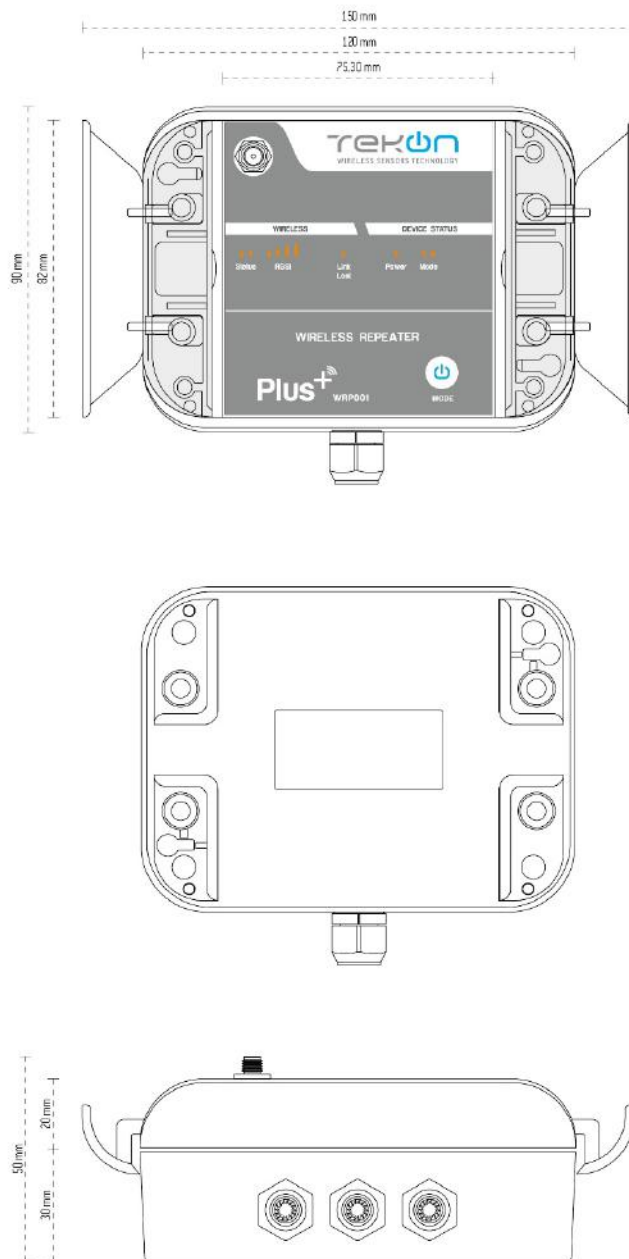

Figure 34 – WRP001 repeater mechanical interface and dimensions

BLOCK DIAGRAM

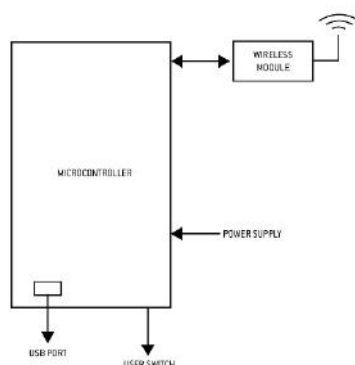

Figure 35 - Block diagram of WRP001 repeater

LABELS



Figure 36 - Labels of WRP001 repeater

LEDS AND BUTTONS WORKFLOW

LED	State	Repeater
Power (Device Status)	Network search	On
	Configuration	On
	Connected	On
Mode (left)	Configuration	Flashes twice alternately with right LED
	Network search	Flashes every second
	Site survey	Flashes twice simultaneously with right LED
Mode (right)	Configuration	Flashes twice alternately with left LED
	Site survey	Flashes twice simultaneously with left LED
Status (wireless) (left) (controlled by RF module)	Network search	Flashes slowly – two seconds On and 2 seconds Off
	Connected	Flashes according to the RSSI level
	Configuration	On
	Site survey	On
Status (wireless) (right) (controlled by RF module)	Network search	Off
	Connected	Flashes five times if connected to the gateway and one time if connected to the repeater
	Configuration	On
	Site survey	On
RSSI	Site survey	Number of LED's on according to the RSSI level of the packets received from the gateway or repeater. Flash simultaneously if no packet is received.
Link Lost	Disconnected (active function)	On when there is a loss of connection to the network and the number of reconnection attempts is equal to the Cycles Number. On or Last State as defined in Startup State

	Connected (active function)	Off when recovering network connection
Internal	Error	Flashes x times according to the problems on the device under automatic diagnosis. Please contact the support to solve the problem.

Table 19 - WRP001 LED behaviours

Button	State	Repeater
Mode	-	Press and hold for 3 seconds to activate the Site Survey mode
	Site survey	Press and hold for 3 seconds to deactivate the Site Survey mode and enters in network connection state
Internal	-	Press and hold for 5 seconds to reset the configurations.

Table 20 - WRP001 buttons behaviours

Configuration

The PLUS WRP001 repeater is a quick setup device, thus promoting the connection to the network of gateway and transmitters. Being a single function device, it is only possible to associate with one network.

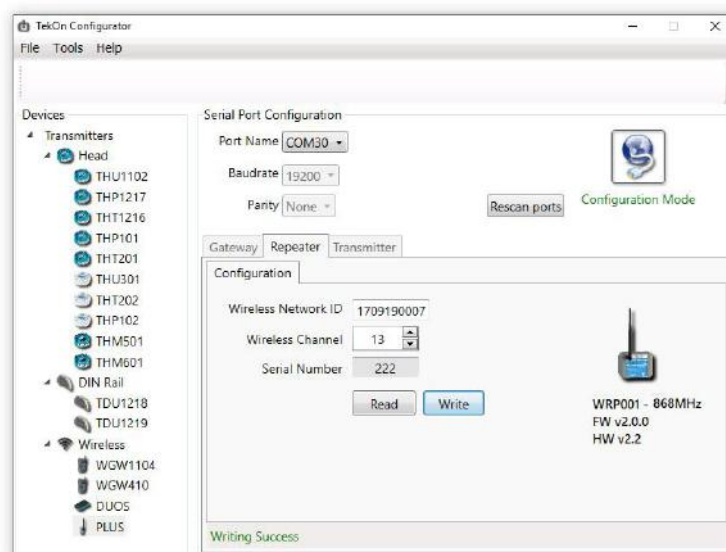

Figure 37 - Configuration of WRP001 repeater at Tekon Configurator software

Configuration

1. Insert the Wireless Network ID and the Wireless Channel.
2. Click on "Write" to save and set the changes.

WIRING

The PLUS Repeater WRP001 has a single wiring for the power supply.

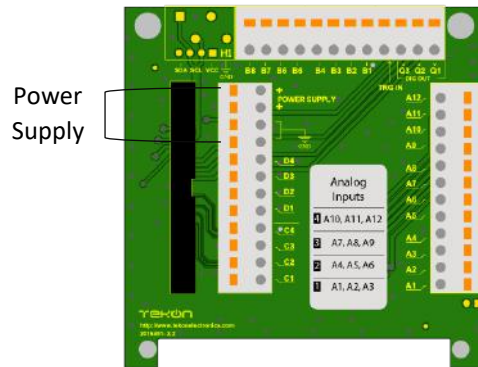

Figure 38 - PLUS Repeater WRP001 wiring

PLUS GATEWAY WG420

MECHANICAL INTERFACE AND DIMENSIONS

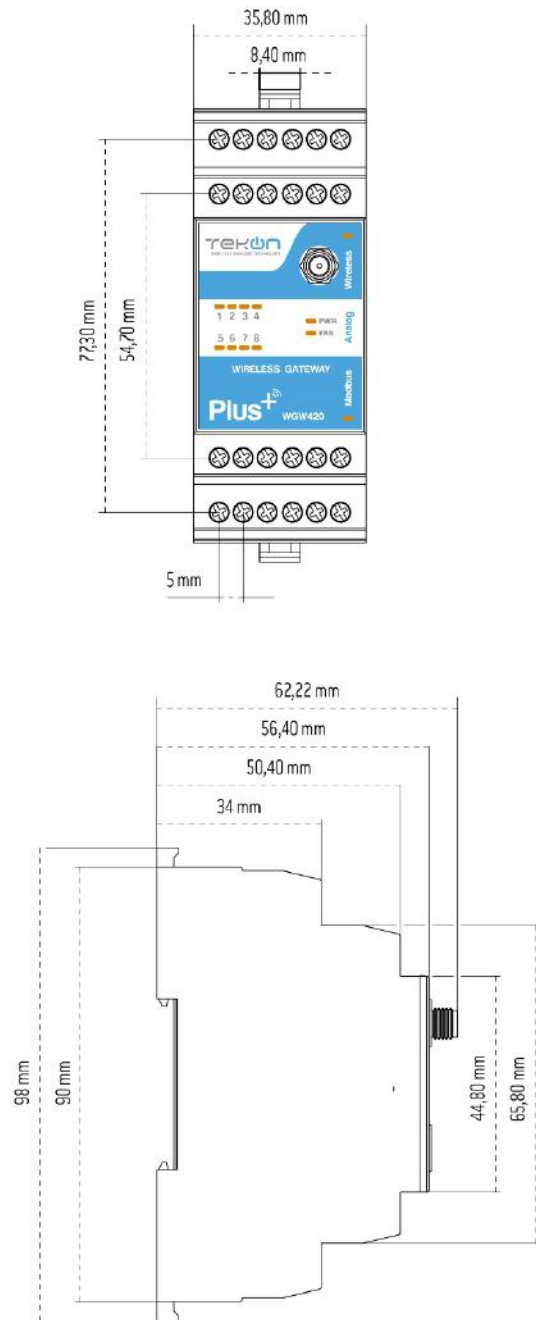

Figure 39 – WG420 gateway mechanical interface and dimensions

BLOCK DIAGRAM

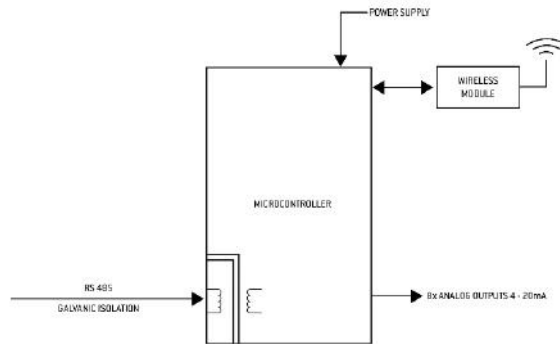

Figure 40 - Block diagram of WGW420 gateway

LABELS



Figure 41 - Labels of WGW420 gateway

LEDS WORKFLOW

LED	State	Gateway
PWR	-	On
ERR	-	Off
Wireless	Normal	Red LED on RF data reception; Green LED on data transmission.
	Boot	Off
	Configuration	Off
Modbus	Normal	Green LED on data reception via RS485; Red LED on data transmission via RS485.
	Boot	Green LED on data reception via RS485;
	Configuration	Green LED on data reception via RS485; Red LED on data transmission via RS485.
8 Analog Outputs	Normal	Red LED if current loop is open; Green LED if respective closed current loop and within the defined representation range; Flashes alternately on time between green and red LED if the current loop is closed and outside the defined representation range;
	Boot	All LED's on in green
	Configuration	Green animation

Table 21 - WGW420 LED behaviours

WIRING

At this section we can check all the wiring connections allowed to the gateway WGW420.

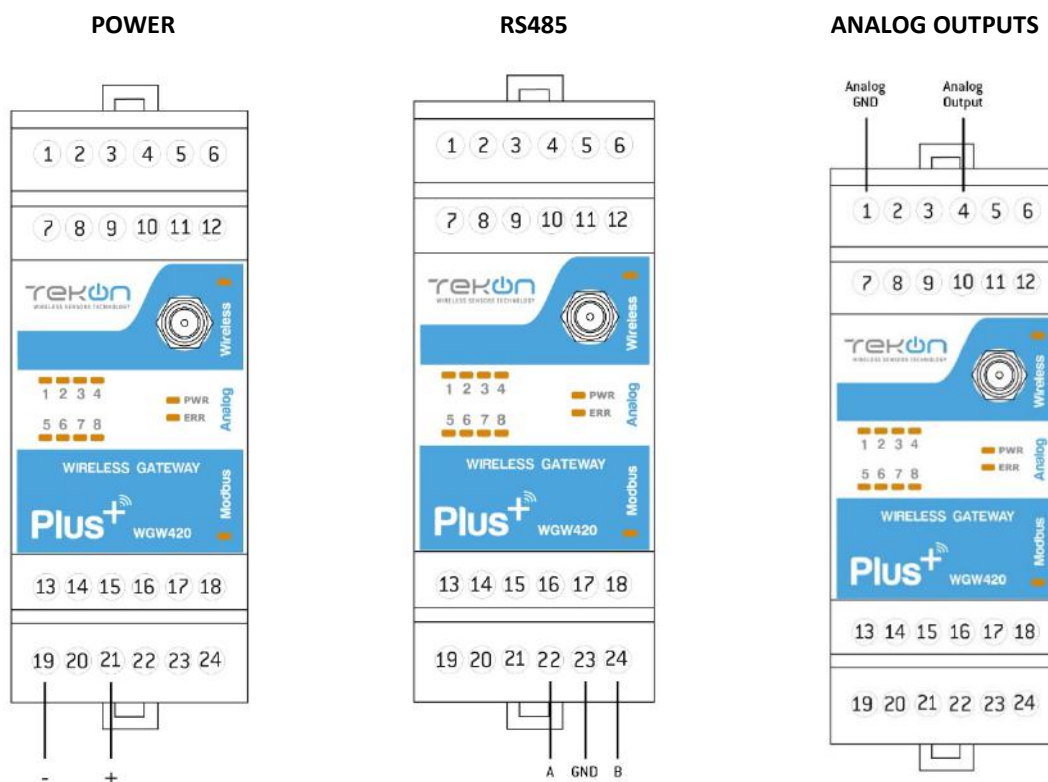

Figure 42 - Connections in PLUS WGW420 gateway

MODBUS

In the Modbus tab, user has direct access to the data coming from the transmitters and can configure the analog outputs of the WGW420 gateway. These values are divided between the Remote Devices and Analog Output tabs.

Description	Address
Serial number	(Transmitter Modbus Index-1) x 20+0
Transmitter model	(Transmitter Modbus Index-1) x 20+2
RSSI	(Transmitter Modbus Index-1) x 20+3
Communication period	(Transmitter Modbus Index-1) x 20+4
Elapsed Time	(Transmitter Modbus Index-1) x 20+5
Power Voltage	(Transmitter Modbus Index-1) x 20+6
Data 0	(Transmitter Modbus Index-1) x 20+7
Data 1	(Transmitter Modbus Index-1) x 20+9
Data 2	(Transmitter Modbus Index-1) x 20+11
Data 3	(Transmitter Modbus Index-1) x 20+13
Data 4	(Transmitter Modbus Index-1) x 20+15
FW version Major Minor	(Transmitter Modbus Index-1) x 20+17

FW version revision	(Transmitter Modbus Index-1) x 20+18
HW version Major Minor	(Transmitter Modbus Index-1) x 20+19

Table 22 - Modbus addresses

REMOTE DEVICES

In this tab, the primary information of each node addresses to the present gateway is displayed. The information is always dependent on the type of transmitter that is connected and is recognized by the software, although some data displayed is common to the several nodes that communicate with the gateway.

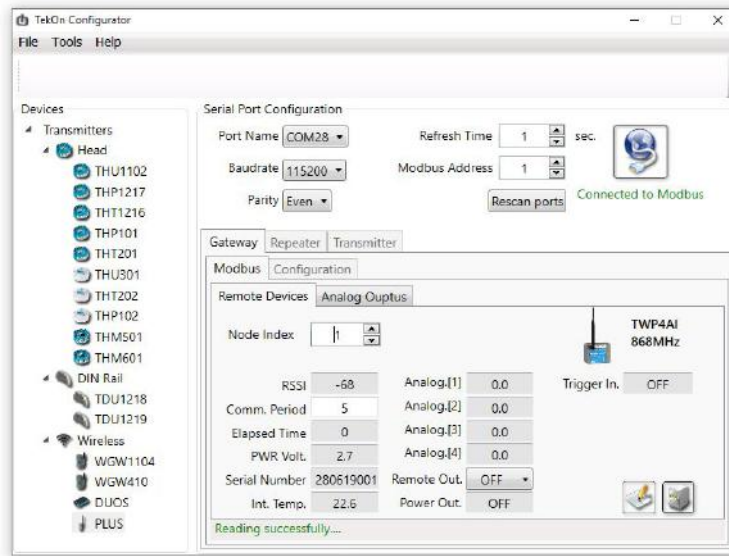

Figure 43 - Tekon Configurator layout of remote devices tab

TAB LAYOUT

Node Index – this field allows the user to choose and navigate among the 55 possible nodes that can connect to a single gateway. The layout of this tab automatically adjusts to each type of transmitter.



Figure 44 - TWP4AI layout of remote devices tab

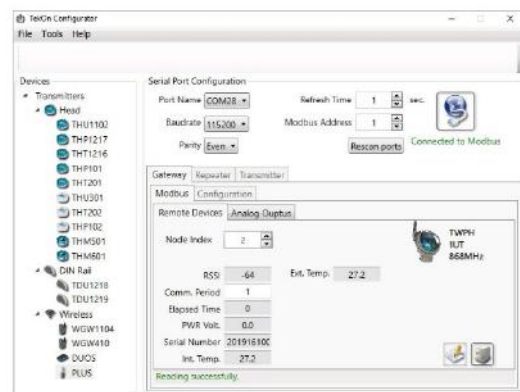

Figure 45 - TWPH-1UT layout of remote devices tab

The layouts from Tekon Configurator have information common to all transmitters and other information that is reserved for the type of transmitter.

COMMON DATA

Variable	Description
RSSI	Received signal strength indication
Comm. Period	Communication period configured for the transmitter
Elapsed Time	Elapsed time since last communication
PWR Volt.	Power voltage (*)
Serial Number	Transmitter serial number
Int. Temp.	Transmitter internal temperature
Ext. Temp.	External Temperature from the sensor input (only on TWP-4AI4DI1UT transmitter)

(*) on the TWPH-1UT transmitter, when powered via USB, the value of this variable is 0.

Table 23 - Description of each label from Tekon Configurator window

TWP4AI

The layout of the Remote Devices tab is complemented with the following fields when a TWP4AI transmitter is connected to the gateway.

Variable	Description
Analog. [1]	Analog input 1 current
Analog. [2]	Analog input 2 current
Analog. [3]	Analog input 3 current
Analog. [4]	Analog input 4 current
Remote Out.	Remote Output state (Configurable)
Power Out.	External power supply to the device
Trigger In.	Trigger input state

Table 24 - Description of each label from Tekon Configurator window (TWP4AI)

TWPH-1UT

The layout of the Remote Devices tab is complemented with the following fields when a TWPH-1UT transmitter is connected to the gateway.

Variable	Description
External Temp.	External temperatura registered through the universal temperature input

Table 25 - Description of each label from Tekon Configurator window (TWPH-1UT)

TWP-4AI4DI1UT

The layout of the Remote Devices tab is complemented with the following fields when a TWP-4AI4DI1UT transmitter is connected to the gateway.

Variable	Description
Analog. [1]	Analog input 1 current
Analog. [2]	Analog input 2 current
Analog. [3]	Analog input 3 current
Analog. [4]	Analog input 4 current
Remote Out.	Remote Output state (Configurable)
Power Out.	External power supply to the device
Trigger In.	Trigger input state
DI 1 2 3 4	Digital input state

Table 26 - Description of each label from Tekon Configurator window (TWP-4AI4DI1UT)

ANALOG OUTPUTS

The WGW420 gateway supports 8 analog outputs with current readings between 4 and 20mA. For each of the outputs, it is possible to associate a Modbus address corresponding to the desired variable.

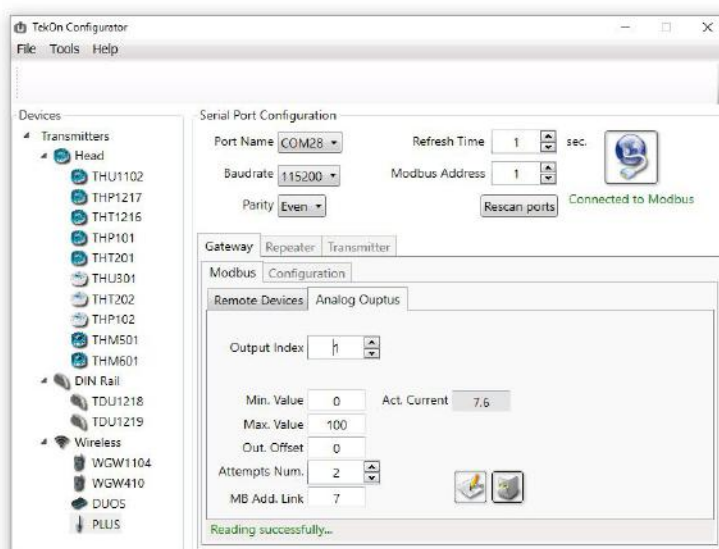

Figure 46 - Tekon Configurator layout of analog outputs tab

In each of the 8 analogic outputs, user can configure the reference values to translate the currents into the desired variable.

Field	Description
Output index	Index of each analog output.
Min. Value	Minimum value equal to the 4mA current
Max. Value	Maximum value equal to the 20mA current
Out. Offset	Current offset in μ A
Attempts Num.	Number of elapsed communications periods without new values and signalize an error.
MB Add. Link	Link to modbus address to convert in current
Act. Current	Actual value registered in this output index.

Table 27 - Description of each label from Tekon Configurator window (Analog outputs)

1. Configuration

Configure the fields the output index;

Click on “Write” icon to set and save the changes.



If the changes are made to the modbus and in run-time, they are permanently safeguarded even after rebooting. It is recommended that the application modbus master guarantees the reconfiguration of the slaves to ensure their smooth operation.

CHAPTER 3 – SYSTEM CONFIGURATION

OPERATION MODE

Each device has a primary purpose within the PLUS product family. The WGW420 gateway is the end device for the entire application, receiving and transmitting data to and from the transmitters. The WRP001 repeater allows to extend the communication range and reinforce the quality of the communication signal.

The transmitters in this family have a dual operating mode that allows it to perform the function of transmitter and repeater. In this characteristic, the mesh network format created by the set of devices is reinforced without the need to add equipment for this purpose.

In the transmitter's configuration process at the Tekon Configurator software, it is possible to select whether it will function as an end device or as a repeater. Please check the installation guide, at Tekon Electronics website, to know how to configure this feature.

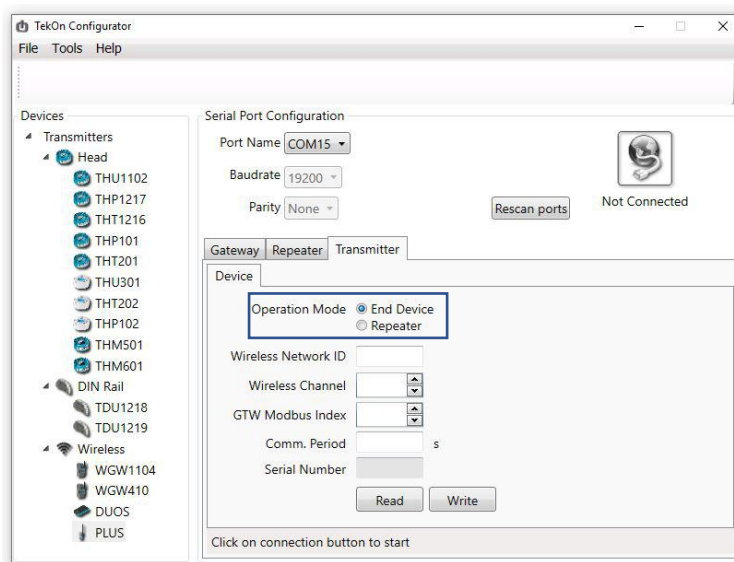

Figure 47 - Transmitter operation mode configuration in Tekon Configurator

SITE SURVEY FEATURE

The transmitters and repeaters in the PLUS product family are equipped with a tool called Site Survey. This feature allows to check whenever necessary the quality of the wireless network created between the devices for communication. This quality helps the user to evaluate the quality of the communication signal and the decision-making to perform the changes to improve this performance, on the field at the installation spot.

This feature is embedded in the repeater and transmitters devices and does not require any additional equipment or software. Please check the installation guide, at Tekon Electronics website or consult the "LED AND BUTTONS DEFINITION" to know how to use this tool in each device.

MODBUS MAPPING

HOLDING REGISTERS – TRANSMITTERS DATA

Description	Address	Number of Words	Data Type	Data
Serial Number	(Transmitter Modbus Index-1) x 20+0	2	UINT32	Transmitter serial number
Transmitter Model	(Transmitter Modbus Index-1)x20+2	1	UINT16	868 MHZ - 09 - TWP4AI 24 - TWP-1UT 37 – TWP-4AI4DI1UT 915MHZ - 26 - TWP4AI 28 - TWP-1UT 38 – TWP-4AI4DI1UT ¹
RSSI	(Transmitter Modbus Index-1)x20+3	1	UINT16	RSSI in dBm = RSSI / -2
Communication Period	(Transmitter Modbus Index-1)x20+4	1	UINT16	Communication Period (seconds)
Elapsed Time	(Transmitter Modbus Index-1)x20+5	1	UINT16	Elapsed Time since last communication (seconds)
Power Voltage	(Transmitter Modbus Index-1)x20+6	1	UINT16	Volts = Power Voltage / 10
Data 0	(Transmitter Modbus Index-1)x20+7	2	FLOAT32	Internal temperature [°C] ●▲; External temperature [°C] ■; ¹
Data 1	(Transmitter Modbus Index-1)x20+9	2	FLOAT32	Analog Input value 1 ●■ ²
Data 2	(Transmitter Modbus Index-1)x20+11	2	FLOAT32	Analog Input value 2 ●■ ²
Data 3	(Transmitter Modbus Index-1)x20+13	2	FLOAT32	Analog Input value 3 ●■ ²
Data 4	(Transmitter Modbus Index-1)x20+15	2	FLOAT32	Analog Input value 4 ●■ ²
FW Version Major Minor	(Transmitter Modbus Index-1)x20+17	1	UINT16	Transmitter Firmware Version ⁴
FW Version Revision	(Transmitter Modbus Index-1)x20+18	1	UINT16	Transmitter Firmware Version ⁴
HW Version Major Minor	(Transmitter Modbus Index-1)x20+19	1	UINT16	Transmitter Firmware Version ⁵

● TWP4AI ▲ TWP-1UT ■ TWP-4AI4DI1UT

Table 28 - Modbus mapping - Holding Registers

¹ Each transmitter model is codified with a unique ID number. Consult specified mapping tables for every transmitter model

² Transmitter internal temperature in degrees Celsius

³ Current in μ A; Voltage in μ V.

⁴ Firmware version: Major.Minor.Revision = 8 MSB.8 LSB.8 LSB

⁵ Hardware version: Major.Minor = 8 MSB.8 LSB

HOLDING REGISTERS – TRANSMITTERS DATA

Description	Address	Number of Words	Data Type	Data
Minimum Value	(Analog Output Index-1)x8+1100+0	2	FLOAT32	Minimum Input Value for current conversion 4mA
Maximum Value	(Analog Output Index-1)x8+1100+2	2	FLOAT32	Maximum Input Value for current conversion 20mA
Output Offset	(Analog Output Index-1)x8+1100+4	1	UINT16	Output current offset in μ A [-1000 to 1000]
Attempts Number	(Analog Output Index-1)x8+1100+5	1	UINT16	Number of Communication Periods to signalize current output error (transmitter disconnected)
Modbus Address Link	(Analog Output Index-1)x8+1100+6	1	UINT16	Words to convert to current. (Start address of Modbus FLOAT32 (2 words) is considered for conversion)
Actual Current Value	(Analog Output Index-1)x8+1100+7	1	UINT16	Actual output analogue current [mA=Actual Current Value/100]

Table 29 - Modbus mapping - Holding Registers - Analog output index

COILS REGISTERS (GATEWAY)

Description	Address	Data
Coil 0	((Modbus Transmitter Index-1)x16)+0	Transmitter Remote control output controlled through Gateway ■ ●
Coil 1	((Modbus Transmitter Index-1)x16)+1	State of External Power Activation output to enable power-on of external devices ■ ●
Coil 2	((Modbus Transmitter Index-1)x16)+2	State of Trigger Input ■ ●
Coil 3	((Modbus Transmitter Index-1)x16)+3	Digital Input 1 state ■
Coil 4	((Modbus Transmitter Index-1)x16)+4	Digital Input 2 state ■
Coil 5	((Modbus Transmitter Index-1)x16)+5	Digital Input 3 state ■
Coil 6	((Modbus Transmitter Index-1)x16)+6	Digital Input 4 state ■
Coil 7	((Modbus Transmitter Index-1)x16)+7	-
Coil 8	((Modbus Transmitter Index-1)x16)+8	-
Coil 9	((Modbus Transmitter Index-1)x16)+9	-
Coil 10	((Modbus Transmitter Index-1)x16)+10	-
Coil 11	((Modbus Transmitter Index-1)x16)+11	-
Coil 12	((Modbus Transmitter Index-1)x16)+12	-
Coil 13	((Modbus Transmitter Index-1)x16)+13	-
Coil 14	((Modbus Transmitter Index-1)x16)+14	-
Coil 15	((Modbus Transmitter Index-1)x16)+15	-

● TWP4AI ▲ TWPH-1UT ■ TWP-4AI4D11UT

Table 30 - Coils address and description

CONFIGURATION

The equipment configuration can be performed in a simple and personalized way. For the configuration you need the following elements:

- Installation guide (available on the Tekon Electronics website for free download);
- Tekon Configurator software (available on the Tekon Electronics website for free download);
- Connection cables required to power the device (applicable to the gateway) and connect to the computer.

APPENDIX**TECHNICAL SPECIFICATIONS****PLUS TRANSMITTER TWP4AI**

RADIO SPECIFICATIONS	868MHZ	915MHZ
Range	Up to 4Km LoS	
Frequency band	868 to 869MHz	902 to 928MHz
Number of channels	16	50
Radio receiver sensitivity	-97 to -110 dBm	
Transmit power	25 to 27 dBm	8 to 27 dBm
Transmission rate	19 to 76,8kbit/s	
Encryption method	AES 128 (Advanced Encryption Standard)	
Modulation	GFSK	
Antenna connector	SMA	
Antenna	Articulated dipole antenna	
Antenna impedance	50Ω	

WIRELESS NETWORK	
Maximum devices	55
Maximum hops	13
Communication period	1 to 43200 seconds (configurable)

INTERNAL TEMPERATURE	
Range	-30 to 80°C
Resolution	0,0625°C
Accuracy	±1°C
Sensor type	Digital sensor

POWER SUPPLY	
Supply voltage	5 to 24V DC ± 5% / USB
Maximum current	500mA DC @ 5V DC / 100mA DC @ 24V DC
Reverse Polarity	

ANALOG INPUT	CURRENT	VOLTAGE
Range	0 to 24mA	0 to 12V DC
Resolution	0,96uA (15bit)	0,38mV (15bit)
Accuracy	<100μA (<0,5% FS)	<5mV (<0,05% FS)
Input impedance	100Ω	>100kΩ

DIGITAL INPUT - TRIGGER	
Range	0V DC to Supply Voltage
ON detection level	>4.5V
OFF detection level	<2.5V
Type	Sinking / NPN
Impedance	>4k Ω
Input current	4,5mA @ 12V DC / 6mA @ 24V DC
Maximum current protection	10mA
Detection type	State change
Activation detection	Falling Edge / Rising Edge / Both

DIGITAL INPUT	COMMUNICATION LOSS	REMOTE OUTPUT	EXTERNAL SUPPLY
Range	5 to 24V DC	5 to 24V DC	5 to 24V DC
Type	Sinking / NPN	Sinking / NPN	Sinking / NPN
Maximum current protection	90mA	90mA	90mA
Start state	ON / OFF / last state	ON / OFF / last state	ON / OFF / last state
Communication loss state	ON / OFF / last state	ON / OFF / last state	ON / OFF / last state
Event number activation	1 to 10	N/A	N/A
Activation period before communication	N/A	N/A	0 to 255 seconds

INTERFACE	
Indication	Frontal Panel LED
Switches	External - Site Survey activation Internal - Load Default Factory Settings
Configuration	Internal micro USB connector

MECHANICAL INTERFACE
Push-in spring terminal blocks (internal)
Bucins PG-7
1.5mm ² (0.0591in)
Micro USB internal connector

OPERATING ENVIRONMENT	ENVIRONMENTAL CONDITIONS	STORAGE CONDITIONS
Temperature	-30 to 80°C	
Relative humidity	N/A	≤ 95% (non- condensing)

PLUS HEAD TRANSMITTER TWPH-1UT

RADIO SPECIFICATIONS	868MHZ	915MHZ
Range	Up to 4Km LoS	
Frequency band	868 to 869MHz	902 to 928MHz
Number of channels	16	50
Radio receiver sensitivity	-97 to -110 dBm	
Transmit power	25 to 27 dBm	8 to 27 dBm
Transmission rate	19 to 76,8kbit/s	
Encryption method	AES 128 (Advanced Encryption Standard)	
Modulation	GFSK	
Antenna connector	SMB	
Antenna	Articulated dipole antenna	
Antenna impedance	50Ω	

WIRELESS NETWORK	
Maximum devices	55
Maximum hops	13
Communication period	1 to 43200 seconds (configurable)

INPUT RESISTANCE THERMOMETER (RTD)	
Measured variable	Temperature
Sensor type	PT100
Units	°C
Connection	1 Resistance thermometer (RTD) in 2-wire, 3-wire or 4-wire system
Sensor current	200µA
Open-circuit monitoring	Always active (cannot be disabled)
Short-circuit monitoring	Always active (cannot be disabled)
Measuring range	See "Digital measuring accuracy" table
Cable resistance per wire (max.)	50 Ω

INPUT THERMOCOUPLES (TC)	
Measured variable	Temperature
Sensor type	Thermocouples: C, J, K, N, R, S, T
Units	°C
Connection	1 Thermocouple
Open-circuit monitoring	Always active (cannot be disabled)
Short-circuit monitoring	Not available
Cold junction compensation (CJC)	Integrated resistance thermometer
Measuring range	See "Digital measuring accuracy" table

POWER SUPPLY	
Voltage Range	5 to 24V DC
Measurement accuracy	± 50mV
Power consumption (sleep)	22 µA @ 12V DC
Protection	Against reversed polarity

MEASUREMENT ACCURACY	
Reference conditions	
Power supply	12V DC \pm 1%
Ambient temperature	23°C
Digital measuring errors	See table "Digital measuring accuracy" table
Internal cold junction	
Accuracy	$< \pm 0,50$ °C
Resolution	0,01 °C
Influence of ambient temperature	
on RTD measurement	$< \pm 0,001$ °C / °C
on thermocouple	Thermocouples C, J, K, N, T: $\leq \pm 0,005$ °C / °C Thermocouple R: $\leq \pm 0,010$ °C / °C Thermocouple S: $\leq \pm 0,2$ °C / °C
EMC - immunity influence (IEC 61326-1)	[To Be Defined]

OPERATING ENVIRONMENT	
Ambient temperature range	-40 to 80°C
Storage temperature range	-40 to 80°C
Relative humidity	$\leq 95\%$, without condensation

DIGITAL MEASURING ACCURACY RESISTANCE THERMOMETER (RTD)			
Sensor	Range °C	Accuracy °C	Resolution °C
PT100	-210 to 850	$< \pm 0,2$	0,05

THERMOCOUPLES (TC)			
Sensor	Range °C	Accuracy °C	Resolution °C
J	-210 to 1200	$< \pm 1,0$	0,077
K	-270 to 1370	$< \pm 1,0$	0,098
N	-270 to 1270	$< \pm 1,0$	0,151
R	-50 to 1760	$< \pm 1,2$	0,189
S	-50 to 1760	$< \pm 2,0$	0,185
T	-270 to 400	$< \pm 1,0$	0,026

PLUS REPEATER WRP001

RADIO SPECIFICATIONS	868MHZ	915MHZ
Range	Up to 4Km LoS	
Frequency band	868 to 869MHz	902 to 928MHz
Number of channels	16	50
Radio receiver sensitivity	-99 to -104 dBm	-97 to -110 dBm
Transmit power	0 to 27 dBm	8 to 27 dBm
Transmission rate	19 to 76,8kbit/s	
Encryption method	AES 128 (Advanced Encryption Standard)	
Modulation	GFSK	
Antenna connector	SMA	
Antenna	Articulated dipole antenna	
Antenna impedance	50Ω	

WIRELESS NETWORK	
Maximum repeaters	12

INTERFACE	
Indication	Frontal Panel LED Internal Service LED
Switches	External - Site Survey activation Internal - Load Default Factory Settings Service LED
Configuration	Internal micro USB connector

MECHANICAL INTERFACE	
Push-in spring terminal blocks (internal)	
Bucins PG-7	
∅ Min:2.5 ∅ Max: 6.5	
1.5mm ² (0.0591in)	
Micro USB internal connector	

POWER SUPPLY	
External	5 to 24V DC ± 5%
USB	Only in configuration
Maximum Current	500mA DC @ 5V DC / 100mA DC @ 24V DC
Reverse Polarity	

OPERATING ENVIRONMENT	ENVIRONMENTAL CONDITIONS	STORAGE CONDITIONS
Temperature	-30 to 80°C	
Relative humidity	N/A	≤ 95% (non- condensing)

PLUS GATEWAY WG420

RADIO SPECIFICATIONS	868MHZ	915MHZ
Range	Up to 4Km LoS	
Frequency band	868 to 869MHz	902 to 928MHz
Number of channels	16	50
Radio receiver sensitivity	-97 to -110 dBm	
Transmit power	25 to 27 dBm	8 to 27 dBm
Transmission rate	19 to 76,8kbit/s	
Encryption method	AES 128 (Advanced Encryption Standard)	
Modulation	GFSK	
Antenna connector	SMA	
Antenna	Articulated dipole antenna	
Antenna impedance	50Ω	

WIRELESS NETWORK	
Maximum devices	55
Maximum hops	13

RS-485 COMMUNICATION	
Protocol	MODBUS RTU (Slave)
Baud rate	4,8 to 115,2kbit/s (configurable)
Parity	none/even/odd (configurable)
Stop bits	1 (even/odd parity) or 2 (none)
Addresses	1 to 247
Galvanic Isolation	1kV AC

POWER SUPPLY	
Supply voltage	12 to 24V DC ± 5%
Current consumption (max.)	100mA DC to 24V DC / 200mA DC to 12V DC
Protection	Against reversed polarity

ANALOG OUTPUT - CURRENT	
Output range	4 to 20mA
Maximum resistive load	360Ω @ 12V DC / 1kΩ @ 24V DC
Out of range	[3,2;4,0] mA and [20,0;20,2] mA
Error indication	3,1mA and 20,4mA
Update period	Equal to wireless communication period (transmitters)
Protection	Against reversed polarity

INTERFACE	
Indicators	Frontal Panel LED
Configuration	RS485 (through RS485 USB)

MECHANICAL INTERFACE	
Maximum wire section	2,5mm ² (0,0984 in)

OPERATING ENVIRONMENT	ENVIRONMENTAL CONDITIONS	STORAGE CONDITIONS
Temperature	0 to 80°C	-20 to 80°C
Relative humidity	N/A	≤ 95% (non- condensing)

PLUS TRANSMITTER TWP-4AI4DI1UT

RADIO SPECIFICATIONS	868MHZ	915MHZ
Range	Up to 4Km LoS	
Frequency band	868 to 869MHz	902 to 928MHz
Number of channels	16	50
Radio receiver sensitivity	-97 to -110 dBm	
Transmit power	25 to 27 dBm	8 to 27 dBm
Transmission rate	19 to 76,8kbit/s	
Encryption method	AES 128 (Advanced Encryption Standard)	
Modulation	GFSK	
Antenna connector	SMA	
Antenna	Articulated dipole antenna	
Antenna impedance	50Ω	

WIRELESS NETWORK	
Maximum devices	55
Maximum hops	13
Communication period	1 to 43200 seconds (configurable)

INPUT RESISTANCE THERMOMETER (RTD)	
Measured variable	Temperature
Sensor type	PT100
Units	°C
Connection	1 Resistance thermometer (RTD) in 3-wire system
Sensor current	200µA
Open-circuit monitoring	Always active (cannot be disabled)
Short-circuit monitoring	Always active (cannot be disabled)
Measuring range	See "Digital measuring accuracy" table
Cable resistance per wire (max.)	50 Ω

INPUT THERMOCOUPLES (TC)	
Measured variable	Temperature
Sensor type	Thermocouples: J, K, N, R, S, T
Units	°C
Connection	1 Thermocouple
Open-circuit monitoring	Always active (cannot be disabled)
Short-circuit monitoring	Not available
Cold junction compensation (CJC)	Integrated resistance thermometer
Measuring range	See "Digital measuring accuracy" table

MEASUREMENT ACCURACY	
Reference conditions	
Power supply	12V DC ± 1%
Ambient temperature	23°C
Digital measuring errors	See table "Digital measuring accuracy" table
Internal cold junction	
Accuracy	< ± 0,50 °C
Resolution	0,01 °C

Influence of ambient temperature on RTD measurement	$\leq \pm 0,001 \text{ } ^\circ\text{C} / \text{ } ^\circ\text{C}$
on thermocouple	Thermocouples J, K, N, T: $\leq \pm 0,005 \text{ } ^\circ\text{C} / \text{ } ^\circ\text{C}$ Thermocouple R: $\leq \pm 0,010 \text{ } ^\circ\text{C} / \text{ } ^\circ\text{C}$ Thermocouple S: $\leq \pm 0,2 \text{ } ^\circ\text{C} / \text{ } ^\circ\text{C}$

POWER SUPPLY	
Supply voltage	5 to 24V DC $\pm 5\%$ / USB
Maximum current	500mA DC @ 5V DC / 100mA DC @ 24V DC
Protection against reverse polarity	

ANALOG INPUT	CURRENT	VOLTAGE
Range	0 to 24mA	0 to 12V DC
Resolution	0,96 μ A (15bit)	0,38mV (15bit)
Accuracy	$<100\mu\text{A}$ ($<0,5\%$ FS)	$<5\text{mV}$ ($<0,05\%$ FS)
Input impedance	100 Ω	$>100\text{k}\Omega$

DIGITAL INPUTS	INPUT TRIGGER	4 DIGITAL INPUTS
Range	0 to 24V DC	
On detection level	$> 4,5 \text{ V}$	$> 12 \text{ V}$
Off detection level	$< 2,5 \text{ V}$	$< 9\text{V}$
Type	Sinking	
Impedance	$> 4\text{k } \Omega$	Compliant to IEC 61131-2; Type 1, 2, 3
Input current	4,5mA @ 12V DC 6mA @ 24V DC	2,47mA for Type 3
Maximum current protection	10mA	
Galvanic isolation	No	Yes
Detection type	State change	
Activation detection (if enabled)	Falling Edge / Raising Edge / Both	

DIGITAL OUTPUT	COMMUNICATION LOSS	REMOTE OUTPUT	EXTERNAL SUPPLY
Range	5 to 24V DC		
Type	Sinking / NPN		
Maximum current protection	90mA		
Start state	ON / OFF / last state		
Communication loss state	ON / OFF / last state		
Event number activation	1 to 10	N/A	N/A
Activation period before communication	N/A	N/A	0 to 255 seconds

INTERFACE	
Indication	Frontal Panel LED Internal Service LED
Switches	External - Site Survey activation Internal - Load Default Factory Settings Service LED
Configuration	Internal micro USB connector

MECHANICAL INTERFACE
Push-in spring terminal blocks (internal)
Bucins PG-7
∅ Min:2.5 ∅ Max: 6.5
1.5mm ² (0.0591in)
Micro USB internal connector

OPERATING ENVIRONMENT	ENVIRONMENTAL CONDITIONS	STORAGE CONDITIONS
Temperature	-30 to 80°C	
Relative humidity	N/A	≤ 95% (non- condensing)

DIGITAL MEASURING ACCURACY RESISTANCE THERMOMETER (RTD)			
Sensor	Range °C	Accuracy °C	Resolution °C
PT100	-210 to 850	< ± 0,2	0,05

THERMOCOUPLES (TC)			
Sensor	Range °C	Accuracy °C	Resolution °C
J	-210 to 1200	< ± 1,0	0,077
K	-270 to 1370	< ± 1,0	0,098
N	-270 to 1270	< ± 1,0	0,151
R	-50 to 1760	< ± 1,2	0,189
S	-50 to 1760	< ± 2,0	0,185
T	-270 to 400	< ± 1,0	0,026



Tekon Electronics

Quinta do Simão
EN109 – Esgueira
3800-230 Aveiro – Portugal
T. +351 234 303 320
M. +351 937 270 062

sales@tekonelectronics.com

www.tekonelectronics.com