

# UNIVERSAL IoT GATEWAY WALL MOUNT CLIP

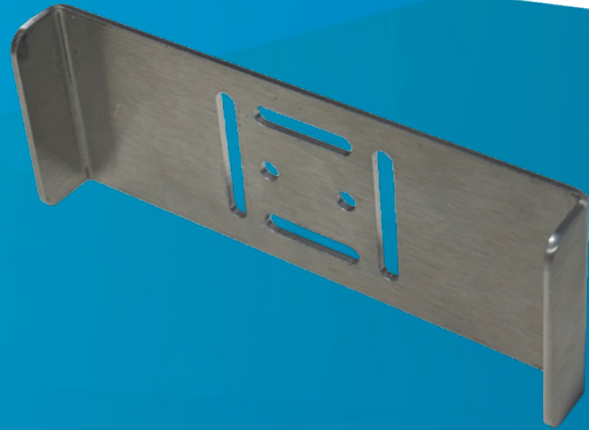

## TECHNICAL SPECIFICATIONS

### REFERENCE

PA123792400

### SPECIFICATIONS

Material	Stainless steel AISI 316L
Dimensions	160,5 x 50 x 17 mm
Weight	130 g
Accessories	Mounting accessories included (screws, plugs, double-sided tape, and cable ties)

### DESENHOS TÉCNICOS

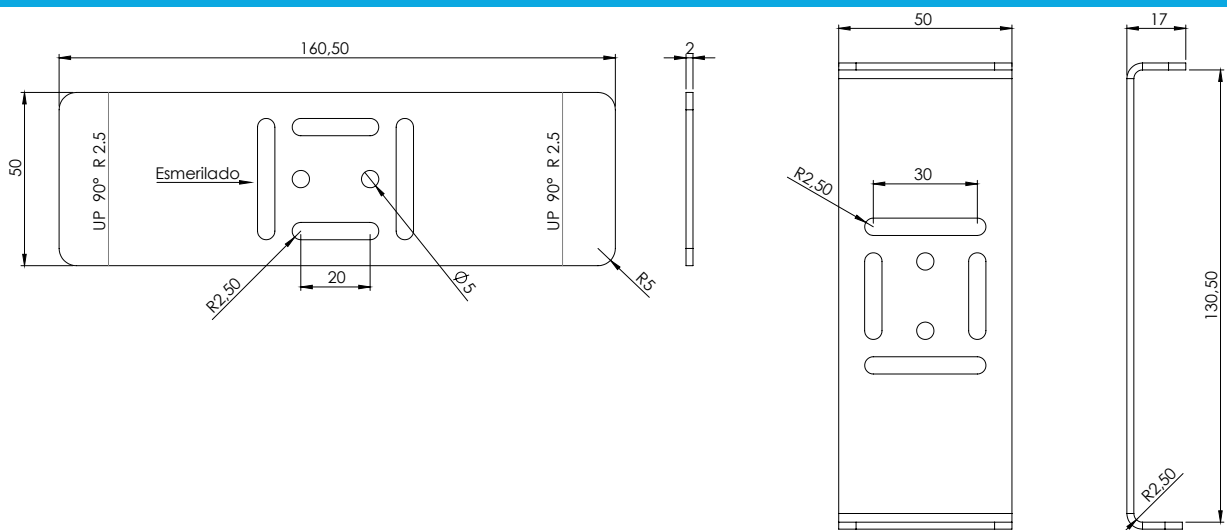

U\_GATEWAY\_WALL\_MOUNT\_E01A

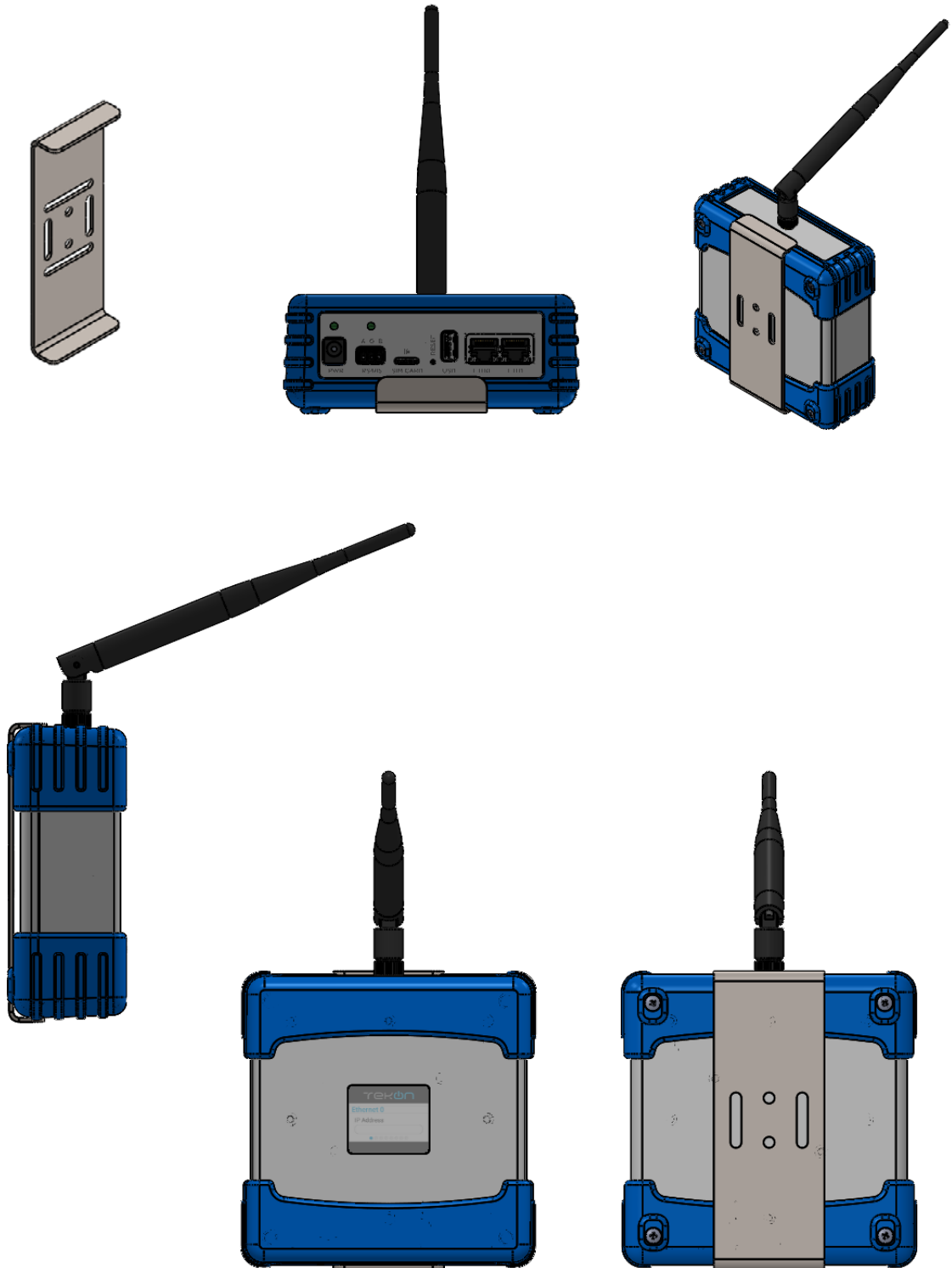

© BRESIMAR AUTOMAÇÃO, S.A.  
All rights reserved.

The contents of this document (texts, images, brands, corporate image, trade name, designs, methodological and product descriptions, among others), as well as its structure and design, are owned by Bresimar Automação, SA [herein in referred to as Bresimar] or, it has legitimacy for its use, being strictly prohibited the modification, exploitation, reproduction, communication to third parties or distribution of all or part of the contents of this document, without the prior express written consent of Bresimar.

Bresimar will not be liable for any claim, loss or damages resulting from or arising from a cause over which Bresimar has no control, whether by acts or omissions, breach of contract or non-compliance with applicable laws by the Supplier, as well as incidents caused by the client's systems.

TEKON ELECTRONICS  
a brand of Bresimar Automação S.A.

Avenida Europa, 460  
Quinta do Simão  
3800-230 Aveiro  
PORTUGAL

P.: +351 234 303 320  
M.: +351 933 033 250  
E.: sales@tekonelectronics.com

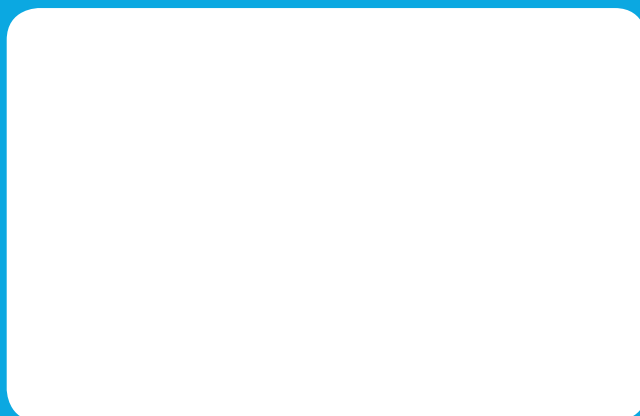

Cofinanciado por:



UNIÃO EUROPEIA  
Fundo Europeu  
de Desenvolvimento Regional